

Technical Description

Master Clock Board for Two Slave Lines
7406



Safety information

The safety regulations and technical data are important for the smooth running of the devices and the protection of people and equipment. Strict compliance with these regulations is required. In case of non-compliance with these regulations the guarantee and warranty claims for the device expire. There is no liability for possible consequential damages.

Safety of the Devices

The production of this device follows the latest technological standards and safety regulations.

The device must not be assembled by anyone but trained personnel. Please make sure that all the connected cables are laid and fixed properly. The device is to be run with the supply voltage stated on the identification plate only.

Only trained personnel or specialists may operate the device.

Repair on opened devices must not be carried out by anyone but specially trained staff or by the *hopf* Elektronik GmbH company.

If the maintenance work requires the opening of a device or if a fuse needs changing the device must be separated from all voltage supplies.

If there are reasons to believe that the operational safety can no longer be guaranteed the device must be taken out of service and labelled accordingly. The safety may be impaired when the device does not operate properly or if it is obviously damaged.

hopf Elektronik GmbH

Nottebohmstr. 41 58511 Lüdenscheid
Postfach 1847 58468 Lüdenscheid

Tel.: ++49 (0)2351 / 9386-86

Fax: ++49 (0)2351 / 9386-93

Internet: <http://www.hopf.com>

e-mail: info@hopf.com

CONTENTS	Page
1 General Information	5
2 Hardware	6
2.1 Front panel components	6
2.2 Hardware Configuration	7
2.2.1 Position Labelling and DIP Switch Assignment	7
2.2.2 Reference number for slave line and addressing of board	8
2.2.3 Setting the duration of the pulse when operating in the old system 7000	9
2.2.4 Configuration of the Line Voltage and Monitoring Equipment	10
2.2.5 Additional Connectors, Jumpers and Bridges	10
2.3 Technical Data	11
3 Configuration of the Master Clock Board 7406	12
3.1 Operating modes of the lines	12
3.1.1 Configuration of the line(s) for clocks with pole-changing pulse mode	12
3.1.1.1 Operation as 2 independent minute slave lines	12
3.1.1.2 Operation as minute and second slave line	12
3.1.1.3 Operation with 12/24-hour output	13
3.1.1.4 Stop for Daylight-Saving Time / Standard Time Changeover	13
3.1.1.5 Time Base of the Line	13
3.1.2 DCF77 Time Code Line	14
3.1.2.1 Time Base for Lines	14
3.2 Error Message	14
3.3 Setting clocks with pole-changing pulse mode	15
3.3.1 Procedure for Setting the Slave Clock Lines in System 6844	15
3.3.1.1 Selection of Slave Clock Line to be configured (1-4) / Slave-Clock-Line (1-4)	15
3.3.1.2 Display the current Data of the selected Slave Clock Line	15
3.3.1.3 Entering the Slave Clock Line Time	16
3.3.1.4 Entering the Slave Clock Line Status (Start / Stop)	16
3.3.1.5 Entering the Slave Clock Line Pulse Time for Pole Changing Pulse Operating	17
3.3.2 Using the Board in System 7001	17
3.4 Setting DCF77 Time Code Clocks	18
4 Errors and their causes	19
4.1 Line error or failure of the line voltage supply	19
4.2 Poling error	19
5 System Functions	20
5.1 Company product update	20
5.2 Board configuration for different bus systems	20
6 Examples of connections	21
6.1 Connector assignment	21
6.2 Pulse type for clocks in pole-changing mode	22
6.3 Pulse type for DCF77 Time Code clocks	22
6.4 Two minute lines and minute and second line (with monitoring)	23
6.5 DCF77 Time Code Clocks (with monitoring)	24
7 Appendix A, System Configuration und Addressing of Board	25

1 General Information

The main clock board 7406 is a slave clock line board for *hopf* GPS and DCF77 19" or ½ 19" (3HE) racks - Systems 7001, 6842 and 6855.

This board can be used for monitoring 2 lines (clock chains) with clocks for pole-changing pulse operation or DCF77 Time Code clocks. The pulse output of the two lines is monitored so that in case of a fault or pulse failure an error message can be made.

- For clocks with pole changing pulse mode:
 - When the equipment has been set the system operates maintenance-free. If there is a fault the actual time of both of the corresponding slave lines are stored so that after the fault has been remedied or when the system is re-started the last time emitted is available and the slave clocks are automatically adjusted.
- For DCF77 Time Code Clocks:
 - The DCF77 Time Code clocks are self-adjusting. For setting the clocks a DCF77 data telegram is required which is transmitted via the line cables. The power supply for the clocks is also provided via the line cables.
 - If there is a fault or a pulse failure or a system failure the DCF77 Time Code clocks continue to be provided with electric current via an additional fixed voltage source which can be connected to the main clock board 7406.

With DCF77 or GPS synchronized clock systems the changeover to summer- and wintertime is automatically recognized and executed. The changeover values must be entered manually by GPS systems.

2 Hardware

2.1 Front panel components

LEDs

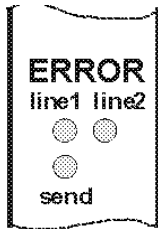

Name	Function
line1	Error LED for line 1
line2	Error LED for line 2
send	Bus communication LED

Assignment of the 24-pole Delta Ribbon Connector

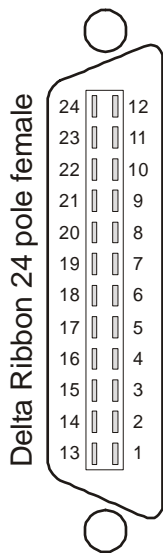

Pin-No.:	Function
1, 13	+Uext, external line voltage supply
2,14,15	-Uext, external line voltage supply (GND_ext)
3	Relay (normally open)
4	Relay (normally closed)
16	Relay (common)
5 / 17	Monitoring input line 1: positive / negative
6 / 18	Pulse output line 1: positive / negative
7 / 19	Monitoring inputs line 2: positive / negative
8 / 20	Pulse outputs line 2: positive / negative
9, 21	+U, additional external line voltage supply
10, 22	-U, additional external line voltage supply (GND_ext)
11	RxD, reception line of the serial interface
12	GND, serial interface
23	unassigned
24	TxD, transmission line of the serial interface

2.2 Hardware Configuration

2.2.1 Position Labelling and DIP Switch Assignment

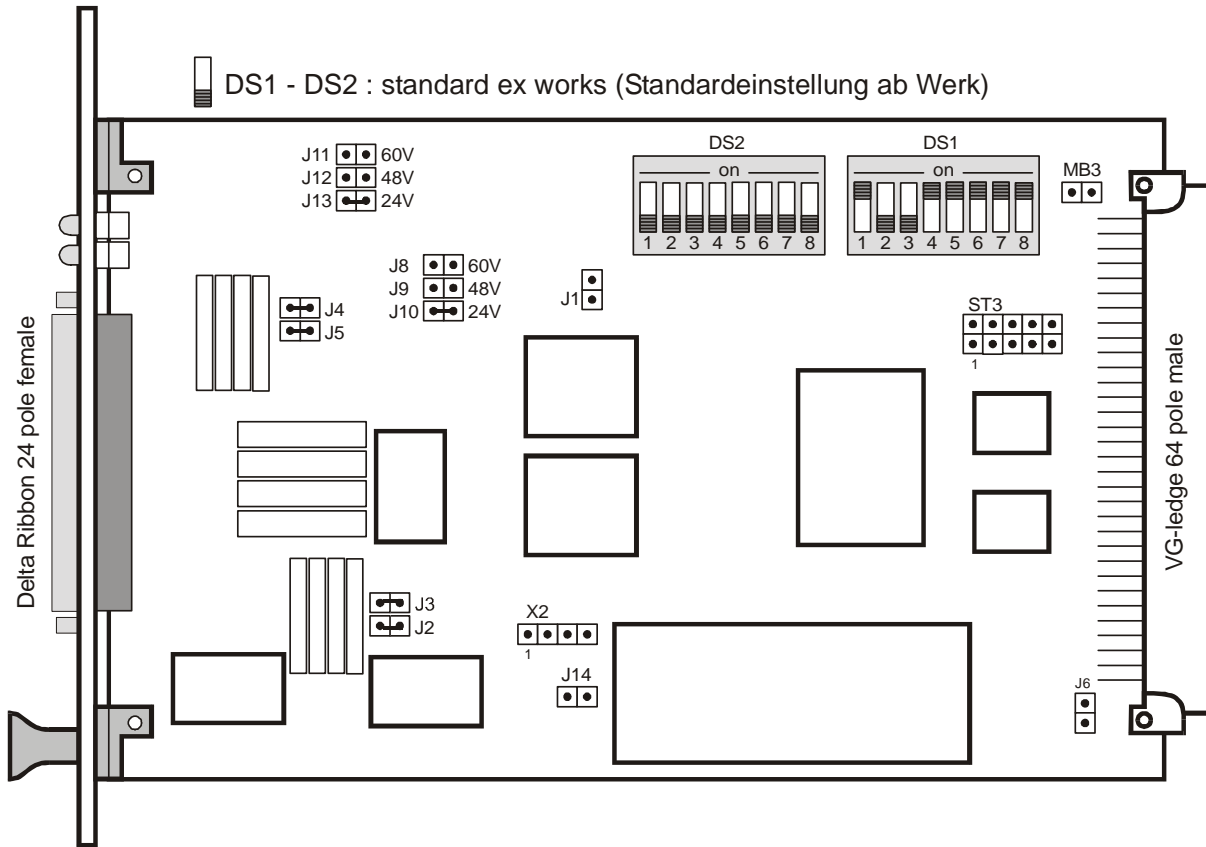

Assignment DIP switch 1 (DS1):

SW	Pos	Function
1	on	12-hour operation slave line 1
	off	24-hour operation slave line 1
2	on	minutes (NL1)+ seconds(NL2)
	off	2 x minute slave lines
3	on	Stop (1h) at changeover summer- / wintertime
	off	Updating display at changeover summer- / wintertime
4	on	12-hour operation slave line 2
	off	24-hour operation slave line 2
5	on	slave line number 1..15 (see chapter 2.2.2)
	off	
6	on	
	off	
7	on	
	off	
8	on	
	off	

Assignment DIP switch 2 (DS2):

SW	Pos	Function
1	on	With radio status error message in collective message
	off	Without radio status error message in collective message
2	on	DCF77 Time Code line
	off	Clocks with pole-changing pulse mode
3	on	Output UTC
	off	Output local time
4	on	68xx Bus
	off	7000, 7001 Bus
5	on	Duration of pulse for old 7000 Bus (see chapter 2.2.3)
	off	
6	on	
	off	
7	on	
	off	
8	on	
	off	

2.2.2 Reference number for slave line and addressing of board

Up to 15 slave lines can be operated simultaneously in one clock system. It is possible to fit an assortment of minute and second and DCF77 Time Code slave lines.

Depending on the operating mode (minute/second, minute/minute or DCF77 Time Code) the board is operated as one or two slave lines and is addressed in the master clock dialog of System 7001.

Table: Reference number of slave line and addressing of board

DIP switch1 (DS1), Switch 5..8

Line no.:	Switch No.:			
	5	6	7	8
1	on	on	on	on
2	on	on	on	off
3	on	on	off	on
4	on	on	off	off
5	on	off	on	on
6	on	off	on	off
7	on	off	off	on
8	on	off	off	off
9	off	on	on	on
10	off	on	on	off
11	off	on	off	on
12	off	on	off	off
13	off	off	on	on
14	off	off	on	off
15	off	off	off	on

Please Note: IN ONE SYSTEM LINE REFERENCE NUMBERS MUST NOT OVERLAP.

Example: for assorted fitting in the systems 68xx, 7000, 7001

Board no.:	DIP switch position DS1				selected lines
	5	6	7	8	
1	on	on	on	on	Line 1 and 2 (min/min)
2	on	on	off	on	Line 3 with second line
3	on	on	off	off	Line 4 and 5 (min/min)
4	on	off	on	off	Line pair 6 and 7 (DCF77 Timecode)

Please Note: THESE SETTINGS SHOULD ONLY BE CARRIED OUT BY QUALIFIED PERSONNEL (FOR ADDRESSING OF THE BOARD REFER TO APPENDIX A)

2.2.3 Setting the duration of the pulse when operating in the old system 7000

When using the master clock board in the old system 7000 it is necessary to set the duration of the pulse of the slave lines for pole-changing pulse operation via the DIP switch **DS2, switch 5..8**, since it is not possible to carry out these adjustments from the system keypad.

The duration of the pulse set via the DIP switch DS2 is only valid for the minute slave lines. When operating with a minute and a second slave line the settings are only valid for the minute line. The second line operates with a permanent pulse duration of 0,2 sec.

Table: Duration of pulse when operating in the old system 7000

DIP-witch2 (DS2), Switch 5..8

Duration of pulse in [msec.]	Switch no.:			
	5	6	7	8
200	on	on	on	on
300	on	on	on	off
400	on	on	off	on
500	on	on	off	off
600	on	off	on	on
700	on	off	on	off
800	on	off	off	on
1.000	on	off	off	off
1.200	off	on	on	on
1.500	off	on	on	off
1.800	off	on	off	on
2.000	off	on	off	off
2.200	off	off	on	on
2.500	off	off	on	off
2.800	off	off	off	on
3.000	off	off	off	off

Please Note: THESE SETTINGS SHULD ONLY BE CARRIED OUT BY QUALIFIED PERSONNEL (FOR ADDRESSING OF THE BOARD REFER TO APPENDIX A).

2.2.4 Configuration of the Line Voltage and Monitoring Equipment

The lines of the master clock board 7406 can be operated with different voltages. For this jumpers 8..13 (refer to position label) must be pre-set for monitoring the voltage.

Table: Jumper setting

Line voltage	Jumper setting		Monitoring voltage
	Line 1	Line 2	
24 V	J13	J10	18 V
48 V	J12	J9	36 V
60 V	J11	J8	45 V

2.2.5 Additional Connectors, Jumpers and Bridges

Table: Additional connectors, jumpers and bridges

Type	Function
ST3	Service connector
X2	Diagnosis connector
J14, J6	Service jumper
MB3, J1	Operating voltage measuring points (5 V DC)
J8, J9, J10	Voltage monitoring setting for line 2
J11, J12, J13	Voltage monitoring setting for line 1
J2, J3	Line 1, Diagnosis jumper
J4, J5	Line 2, Diagnosis jumper

2.3 Technical Data

General information	Euro board 160 x 100 mm (4HP) for 19" and/or. ½ 19" (3U) racks
Voltage supply	
Internal system voltage	min. 4,8 V max. 5,2 v DC
Line voltage (external)	24..60 V / 1 A per line
Line voltage (internal, optional)	24..60 V / 500 mA per line (other voltages available on request)
Number of slave lines	max. 2
Alarm relay	
Contact load	24 v / 20 mA
Line changeover relay	
Contact load	24..60 V / 1 A
Temperature range	0 - 50°C 0 - 70°C with restricted freewheeling properties
MTBF	> 600.000 h
Accuracy (internal)	
Second mark on GPS	± 1 µsec
Second mark on DCF77	± 2 msec

Please Note: FOR SPECIAL PRODUCTS HARD- AND SOFTWARE MODIFICATIONS ARE POSSIBLE ON REQUEST.

3 Configuration of the Master Clock Board 7406

3.1 Operating modes of the lines

It is possible to configure the 7406 board for the operation of clocks with pole-changing pulse operation or DCF77 Time Code clocks.

DIP-switch **DS2**; switch **2 = off** ⇒ for clocks with pole-operating pulse operation
DIP switch **DS2**; switch **2 = on** ⇒ for DCF77 Time Code clocks

3.1.1 Configuration of the line(s) for clocks with pole-changing pulse mode

In this mode it is possible to drive either 2 minute lines or 1 minute and 1 second line, whereby in the operating mode minute with second line both pulse outputs for a slave line are required.

The pulse output of both lines is monitored. When the line voltage drops below a certain level, or if the cable breaks or the system fails an error message is made and shown via the alarm relay. The time which was last transmitted is always stored so that after the fault has been remedied the clocks can be re-set maintenance-free and automatically.

3.1.1.1 Operation as 2 independent minute slave lines

DIP switch **DS1**; Switch **2 = off** ⇒ 2 independent minute slave lines

Both lines of the board are used to drive minute-slave clock chains.

Please Note: THE BOARD USES TWO LINE REFERENCE NUMBERS IN THE SYSTEM.

3.1.1.2 Operation as minute and second slave line

DIP- switch **DS1**; switch **2 = on** ⇒ 1 minute line and 1 second line

The second line of the board is used for driving second lines.

Please Note: IN THIS SETTING ONLY ONE LINE REFERENCE NUMBER IN THE SYSTEM IS USED.

3.1.1.3 Operation with 12/24-hour output

The two lines on the board can operate with the different hour display.

Slave line 1:

- DIP switch **DS1**; switch **1** = **on** ⇨ 12 hour operation
- DIP switch **DS1**; switch **1** = **off** ⇨ 24 hour operation

Slave line 2:

- DIP switch **DS1**; switch **4** = **on** ⇨ 12 hour operation
- DIP switch **DS1**; switch **4** = **off** ⇨ 24 hour operation

3.1.1.4 Stop for Daylight-Saving Time¹ / Standard Time Changeover²

- DIP switch **DS1**; switch **3** = **on** ⇨ 1 hour - Stop at ST ⇨ WT

When this function has been activated the minute lines wait for 1 hour after the changeover from daylight-saving to standard time.

Please Note: THIS FUNCTION IS ACTIVATED AUTOMATICALLY WITH MINUTE LINES IN 24 HOUR OPERATION, INDEPENDENT OF THE DIP SETTINGS, SO THAT A CHANGE OF DATE IS AVOIDED.

- DIP switch **DS1**; switch **3** = **off** ⇨ Updating display (11/23 h forerun) at ST ⇨ WT

When this function has been activated the minute line is re-set after the changeover from daylight-saving to standard time.

3.1.1.5 Time Base of the Line

In the following configuration the line output time for the clocks is set.

- DIP switch **DS2**; switch **3** = **off** ⇨ output local time
- DIP switch **DS2**; switch **3** = **on** ⇨ output UTC time

Please Note: WHEN SETTING THE CLOCKS IN THE POLE-CHANGING PULSE MODE THE SLAVE LINE TIME MUST BE SET CORRECTLY AS UTC OR LOCAL TIME.

¹ Daylight-Saving Time ⇨ Summer Time (ST)

² Standard Time ⇨ Winter Time (WT)

3.1.2 DCF77 Time Code Line

In this mode 2 DCF77 Time Code lines are available for slave clocks.

DIP switch **DS2**; switch **2 = on** ⇒ DCF77 Time Code Line

Please Note: THE BOARD USES TWO LINE REFERENCE NUMBERS IN THE SYSTEM.

3.1.2.1 Time Base for Lines

The line output time for clocks is set with the following configuration.

DIP switch **DS2**; switch **3 = off** ⇒ output local time

DIP switch **DS2**; switch **3 = on** ⇒ output UTC time

3.2 Error Message

When the alarm relay is set off this draws attention to any errors and these are emitted as a collective message. If there are no errors or faults the relay picks up. The following errors are reported:

- System or master clock board 7406 fails or the mains unit is faulty
- Error in line 1 or line 2 (e.g.: failure of external or internal line voltage supply, external line interrupted or short-circuited)
- The synchronisation of the system is faulty

With the DIP switch 2 (DS2) switch 1 the error message "no synchronisation of the whole system" can be added to the collective message.

DIP switch **DS2**; switch **1 = on** ⇒ radio-synchronisation error message contained in collective message

DIP switch **DS2**; switch **1 = off** ⇒ radio-synchronisation error message **not** contained in collective message

3.3 Setting clocks with pole-changing pulse mode

3.3.1 Procedure for Setting the Slave Clock Lines in System 6844

If the board 7406 is operated in system 6844 (3U or 1U version) the menu structure is explained in the appropriate system description.

3.3.1.1 Selection of Slave Clock Line to be configured (1-4) / Slave-Clock-Line (1-4)

Selection frame:

S	L	A	V	E		C	L	O	C	K		
L	I	N	E		1	.	.	4		>	_	

Depending on the used operation mode in board 7406 up to four independent slave clock lines can be configured in System 6844.

3.3.1.2 Display the current Data of the selected Slave Clock Line

Selection frame:

S	L	A	V	E		C	L	K		L	I	N	E	.	1
S	H	O	W		D	A	T	A		Y	/	N			

Display frame:

S	C	L	.	1		R		1	3	:	2	5	:	2	1										
L	i	n	e		d	a	t	a		0	.	2		s	e	c		2	3	/	0	2	/	1	0

Display	Remark
SCL.1	Line 1
R	Status of the slave clock line active (R=Run / S=Stop)
13:25:21	Actual slave clock line time (hh:mm:ss)
0,2sec	Pulse duration for slave clock line
23/02/10	Actual slave clock line date (TT:MM:JJ)



Before setting the time of the slave clock line, a stop the slave clock line is recommended.

3.3.1.3 Entering the Slave Clock Line Time

To set the slave lines to the current time (e.g. on first installation or after maintenance work) the slave line time must be re-entered. Care should be taken to ensure that all clocks connected to the line are displaying the same time (e.g. 12.00.00). This time is then entered under **Set Time**.



The line is automatically synchronised with the system time after the new slave line time has been re-entered (⇒ Status of the Slave Clock Line = active / R).

Selection frame:

S	L	A	V	E		C	L	K		L	I	N	E	.	1
		S	E	T		T	I	M	E		Y	/	N		

Input frame:

S	C	L	.	1		S	E	T		T	I	M	E		
		>	_	:		:		:							

Display	Remark
SCL.1	Line 1
>_:_:_::_	Entering the actual slave clock line time (hh:mm:ss).

3.3.1.4 Entering the Slave Clock Line Status (Start / Stop)

The status of the slave clock line enables stopping of the complete slave clock line for service purposes and its re-start.

Selection frame:

S	L	A	V	E		C	L	K		L	I	N	E	.	1
		R	U	N	/	S	T	O	P		Y	/	N		

Input frame:

S	C	L	.	1		R	U	N	:		+				
						S	T	O	P	:		-			

Display frame::

S	C	L	.	1		R		1	3	:	2	5	:	2	1					
						0	.	2	s	e	c		2	3	/	0	2	/	1	0

Input	Remark
STOP: -	Slave Clock Line Stop (pulse output inactive) The complete slave clock line is stopped (the time of the slave clock line is not going on in the System)
RUN: +	Slave Clock Line Run (pulse output active) The complete slave clock line is started and its displayed time set to system time.

3.3.1.5 Entering the Slave Clock Line Pulse Time for Pole Changing Pulse Operating

The pulse time can be extended for slow-acting clockworks (e.g. due to large, heavy pointers).

Selection frame:

S	L	A	V	E		C	L	K		L	I	N	E	.	1
P	U	L	S	E		W	I	D	T		Y	/	N		

Display frame:

S	C	L	.	1		P	U	L	.	W	I	D	T		

The pulse time is adjustable in 0.1 second steps from 0.2 up to 3.0 with the key and key . The entered pulse time needs to be confirmed with the key .

Pulse times that are too short on slow-acting clockworks can cause faulty time transfer on individual clocks in the line. For this reason the pulse time is adjusted for the slowest-acting clock in the line.

The pulse time of the **second lines** is not adjustable; this is fixed at 0.2 sec.

3.3.2 Using the Board in System 7001

If the board 7406 is operated in system 7001 with control board 7020 the menu structure is explained in the appropriate system description.

In System 7001 (01..15)

Selection frame (System 7001):

S	.	-	C	L	K	N	o	:	0	1	S	T	=	R	I	=	1	.	0	s	T	:	1	1	.	5	0	.	4	1			
N	E	W	I	N	P	U	T	>	_	<	>	<	>	.	s	<	>

The configuration of the slave clock line is determined column-by-column. In the first line of the display the data of the currently requested slave clock line are described. In the second line the displayed slave clock line can be re-parameterized.

Display	Remark																						
<table border="1" style="background-color: #008000; color: white; text-align: center; font-family: monospace;"> <tr><td>S</td><td>.</td><td>-</td><td>C</td><td>L</td><td>K</td><td>N</td><td>o</td><td>:</td><td>0</td><td>1</td></tr> <tr><td>N</td><td>E</td><td>W</td><td>I</td><td>N</td><td>P</td><td>U</td><td>T</td><td>></td><td>_</td><td><</td></tr> </table>	S	.	-	C	L	K	N	o	:	0	1	N	E	W	I	N	P	U	T	>	_	<	<p>Line number Slave Clock Line 01 to 15 are for disposal</p>
S	.	-	C	L	K	N	o	:	0	1													
N	E	W	I	N	P	U	T	>	_	<													
<table border="1" style="background-color: #008000; color: white; text-align: center; font-family: monospace;"> <tr><td>S</td><td>T</td><td>=</td><td>R</td></tr> <tr><td>></td><td><</td><td>></td><td><</td></tr> </table>	S	T	=	R	>	<	>	<	<p>Status of the slave clock line ST=S ⇔ Slave Clock Line Stop (pulse output inactive) The complete slave clock line is stopped (the time of the slave clock line is not going on in the System) ST=R ⇔ Slave Clock Line Run (pulse output active) The complete slave clock line is started and its displayed time set to system time.</p>														
S	T	=	R																				
>	<	>	<																				
<table border="1" style="background-color: #008000; color: white; text-align: center; font-family: monospace;"> <tr><td>I</td><td>=</td><td>1</td><td>.</td><td>0</td><td>s</td></tr> <tr><td>></td><td>.</td><td>s</td><td><</td><td></td><td></td></tr> </table>	I	=	1	.	0	s	>	.	s	<			<p>Pulse length The pulse time is adjustable in 0.1 second steps from 0.2 to 3.0 seconds. Here 1,0 seconds.</p>										
I	=	1	.	0	s																		
>	.	s	<																				
<table border="1" style="background-color: #008000; color: white; text-align: center; font-family: monospace;"> <tr><td>T</td><td>:</td><td>1</td><td>1</td><td>.</td><td>5</td><td>0</td><td>.</td><td>4</td><td>1</td></tr> <tr><td>></td><td>.</td><td>.</td><td>.</td><td>.</td><td>.</td><td>.</td><td>.</td><td>.</td><td><</td></tr> </table>	T	:	1	1	.	5	0	.	4	1	>	<	<p>Time of the slave clock line In hour, minute and second (hh:mm:ss).</p>		
T	:	1	1	.	5	0	.	4	1														
>	<														

Input of Slave Clock Line Number

If the data of the other slave clock lines are to be queried or changed the slave clock line number must be entered in the second line. The input of the number is in **two digits** in the range from **01..15**. If the input of the number is outside the permissible range an error message will appear.

After input of the slave clock line number the first line in the display is updated accordingly, if the slave clock line entered is available within the system.

Input of Slave Clock Line Status

Here the input of S(top) can stop slave clock line pulse output or the input of R(un) can start slave clock line pulse output.

Input of Slave Clock Line Pulse Length

Here the pulse length can be set in the range of 0.2 .. 3.0 seconds. If the input of the pulse length is outside the permissible range the minimal 0.2 or maximal 3.0 seconds pulse length is pre-set.

Input of Slave Clock Line Time

Here the slave clock line time is re-set. The slave clock line time is entered according to the **hh.mm.ss** format/sample, whereby the following inputs are possible:

hh	hour	range	from 00 - 23
mm	minute	— " —	from 00 - 59
ss	second	— " —	from 00 – 59



Before the Slave clock line time is set, stopping the slave clock line is recommended.

3.4 Setting DCF77 Time Code Clocks

The DCF77 Time Code clocks are set automatically as soon as the DCF77 time telegram has been read in correctly (refer to Appendix DCF77, Technical Description DCF77 Time Code Clocks).

The DCF77 time telegram and the voltage supply are transmitted via the line cables.

4 Errors and their causes

4.1 Line error or failure of the line voltage supply

A short circuit or a broken cable in parts of the equipment can interfere with the output of pulses.

By feeding the slave lines back to the monitoring inputs, errors such as short circuits, failure of the line voltage supply, falling below the line monitoring voltage set or a broken cable in the clock equipment can be recognised and this will be indicated via the LEDs or the alarm relay.

- For clocks with pole-changing mode:
 - If one of the above-mentioned errors occurs the master clock board stops the output of pole-changing pulses. The alarm relay is activated and the message "error LED" of the fault line(s) lights up in the front panel.
 - An attempt is made to make up for the missed pulses until the line monitor has measured a sufficiently high voltage at the monitor inputs.
 - When the damage has been remedied the missed pulses are made up for automatically, so that no additional setting of the clocks is necessary.
- For DCF77 Time Code clocks:
 - If one of the above-mentioned errors occurs the master clock board stops the output of the DCF77 time telegram. The lines are switched to "reserve voltage supply" so that the DCF77 Time Code clocks continue in quartz operation. The alarm relay is activated and the corresponding "Error LED" lights up in the front panel.
 - After approx. 10 minutes the operation switches back to line voltage supply to check whether the fault has been eliminated. If this is not the case the check is repeated again every 10 minutes until the fault is eliminated.
 - When the fault has been eliminated the output of the DCF77 time telegram continues and the clocks are once again supplied with voltage from the "standard voltage supply".

4.2 Poling error

The most common error is the incorrect poling of individual clocks or of the whole slave clock chain for pole-changing pulse mode.

Effect:

Individual clocks or the complete clock line lag one pulse behind. Even when the corresponding line is stopped the clocks affected still miss one pulse.

Remedy:

- stop slave clock via the menu
- interchange the connector(s) of the clock (chain) affected
- read the time from the slave line and enter this as a new slave line time in the menu

5 System Functions

5.1 Company product update

The 7406 board can be updated with new programmes via the external serial interface (RS232) of the 24-pole Delta Ribbon connector of the master clock board.

Please Note: PLEASE CONTACT *HOPF* ELEKTRONIK IF NECESSARY!

5.2 Board configuration for different bus systems

The 7406 board is compatible with the old 7000 Bus (with 7010, master clock 6) and the 7001 Bus (with 7015). No manual intervention in the board settings is required for the 7000 / 7001 Bus configuration.

If the board is operated in the 68xx (6841, 6842, 6844 or 6855) systems, the following configuration is necessary:

DIP switch DS2 ; switch 4 = off	⇒	7000 / 7001 System
DIP switch DS2 ; switch 4 = on	⇒	68xx System

Please Note: THE FOLLOWING SETTINGS SHOULD ONLY BE CARRIED OUT BY QUALIFIED PERSONNEL!

6 Examples of connections

6.1 Connector assignment

Assignment of the 24 Pole Delta Ribbon Connector in the Front Panel

Belegung der 24 poligen Delta-Ribbon-Buchse in der Frontblende

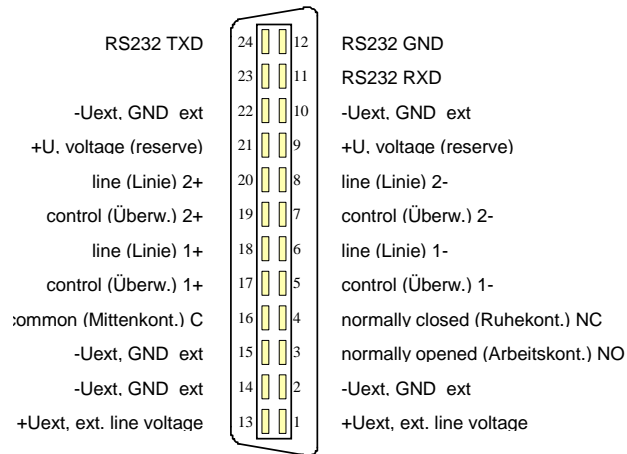

6.2 Pulse type for clocks in pole-changing mode

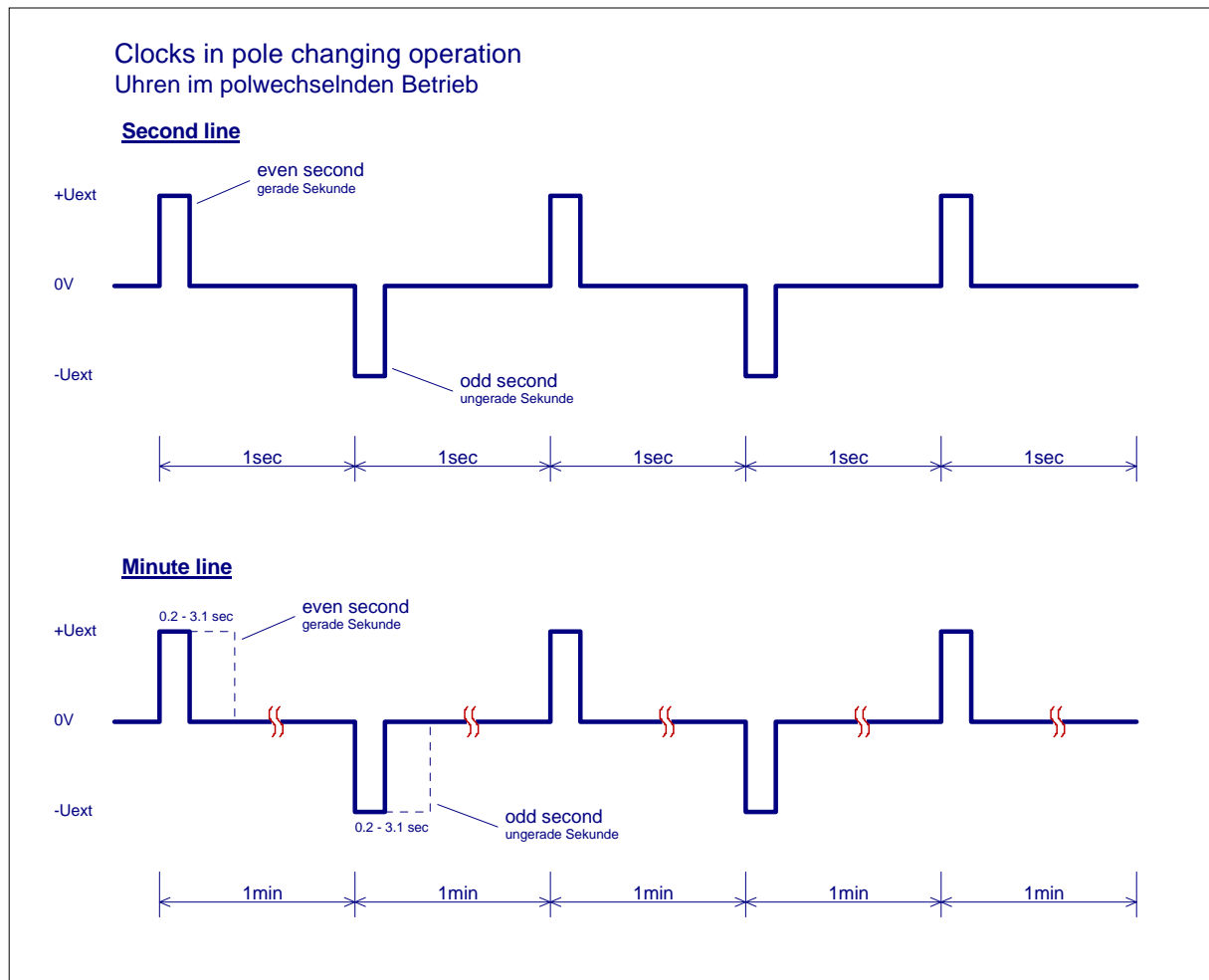

6.3 Pulse type for DCF77 Time Code clocks

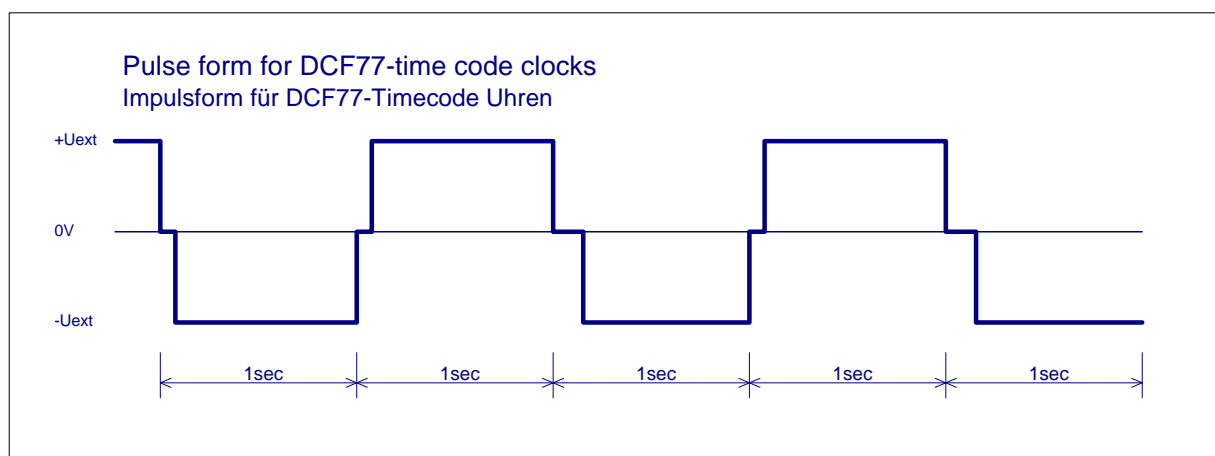

6.4 Two minute lines and minute and second line (with monitoring)

Connection Examples for Two Minute Lines
(with voltage monitoring)

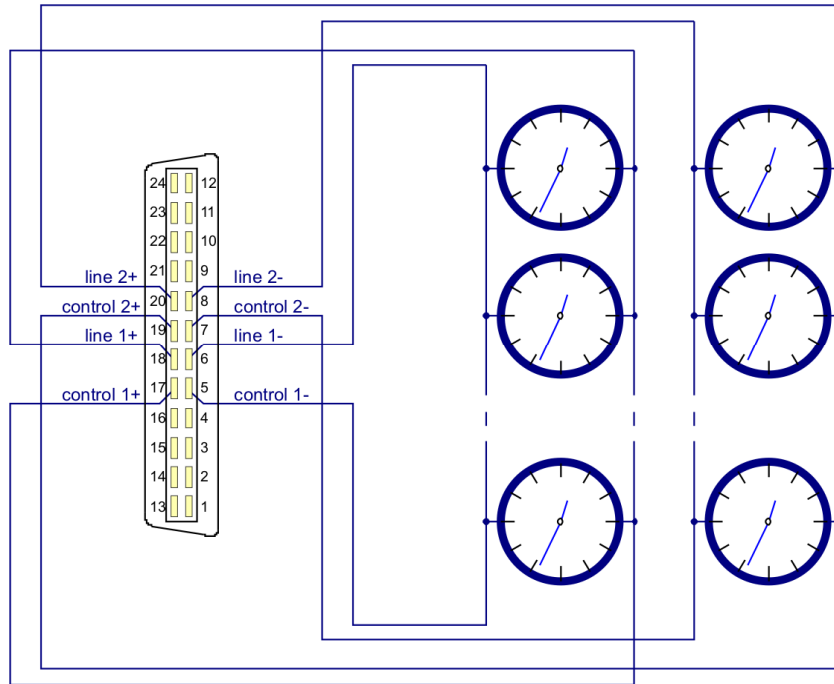

Connection Example for Minute and Second Line
(with voltage monitoring)

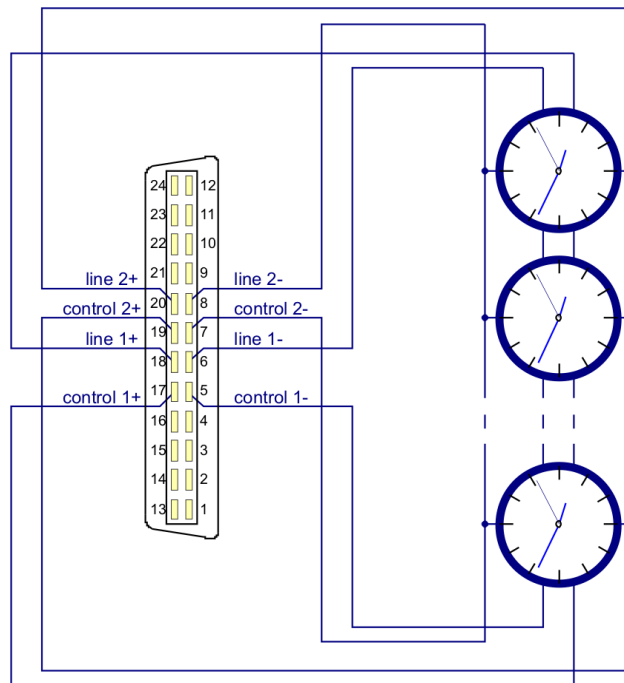

6.5 DCF77 Time Code Clocks (with monitoring)

Connection Example for DCF77 Time Code Clocks
(with voltage monitoring)

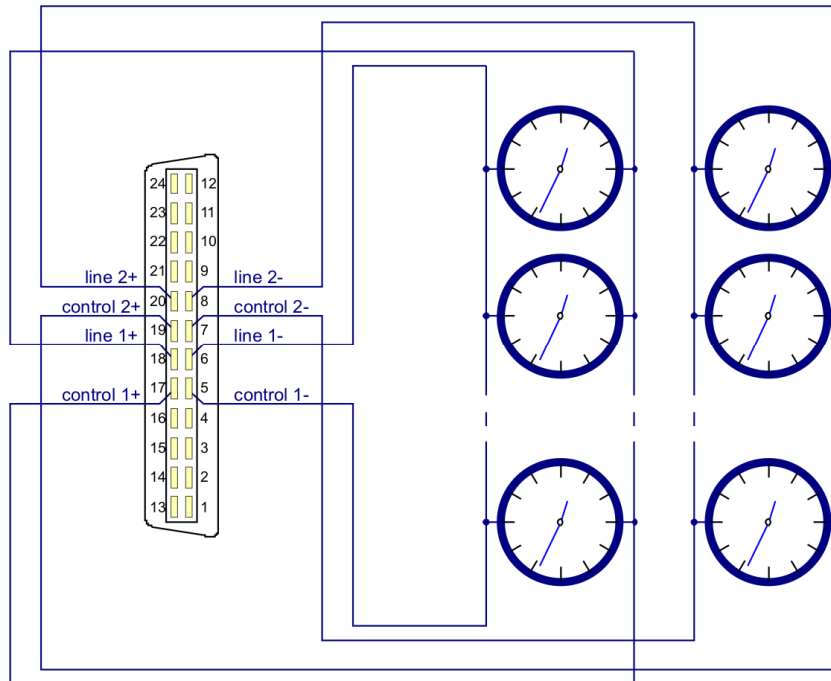

Please Note: IF NO PULSE MONITORING IS REQUIRED THE PINS CAN BE CLOSED DIRECTLY TO THE 24-POLE DELTA RIBBON CONNECTOR.

7 Appendix A, System Configuration und Addressing of Board

To be filled in by the tester: Name: _____ Date: _____

Voltage supply: internal ⇒ ___ volt ___ ampere
 external

Functions:

- A: minute/minute, 12h output
- B: minute/second, 12h output
- C: minute/minute, 24h output
- D: minute/second, 24h output
- E: DCF77 Time Code Line

Board 1: Line No.: _____ / _____ , Function: _____

Board 2: Line No.: _____ / _____ , Function: _____

Board 3: Line No.: _____ / _____ , Function: _____

Board 4: Line No.: _____ / _____ , Function: _____

Board 5: Line No.: _____ / _____ , Function: _____

Board 6: Line No.: _____ / _____ , Function: _____

Board 7: Line No.: _____ / _____ , Function: _____

Board 8: Line No.: _____ / _____ , Function: _____

Board 9: Line No.: _____ / _____ , Function: _____

Board 10: Line No.: _____ / _____ , Function: _____

Board 11: Line No.: _____ / _____ , Function: _____

Board 12: Line No.: _____ / _____ , Function: _____

Board 13: Line No.: _____ / _____ , Function: _____

Board 14: Line No.: _____ / _____ , Function: _____

Board 15: Line No.: _____ / _____ , Function: _____