

Industriefunkuhren



Technical Manual

Subsystem

Model 4475

ENGLISH

Version: 04.00 – 22.01.2009

Valid for Devices 4475 with FIRMWARE Version: **04.xx**
and HMC REMOTE-SOFTWARE Version: **01.06**

Version number (Firmware / Manual)

THE FIRST TWO DIGITS OF THE VERSION NUMBER OF THE TECHNICAL MANUAL AND THE FIRST TWO DIGITS OF THE FIRMWARE VERSION MUST **COMPLY WITH EACH OTHER**. THEY INDICATE THE FUNCTIONAL CORRELATION BETWEEN DEVICE AND TECHNICAL MANUAL.

THE DIGITS AFTER THE POINT IN THE VERSION NUMBER INDICATE CORRECTIONS IN THE FIRMWARE / MANUAL THAT ARE OF NO SIGNIFICANCE FOR THE FUNCTION.

Downloading Technical Manuals

All current manuals of our products are available free of charge via our homepage on the Internet.

Homepage: <http://www.hopf.com>

E-Mail: info@hopf.com

Symbols and Characters



Operational Reliability

Disregard may cause damages to persons or material.



Functionality

Disregard may impact function of system/device.



Information

Notes and Information.



Safety regulations

The safety regulations and observance of the technical data serve to ensure trouble-free operation of the device and protection of persons and material. It is therefore of utmost importance to observe and compliance with these regulations.

If these are not complied with, then no claims may be made under the terms of the warranty and no liability will be assumed for any ensuing damage.



Safety of the device

This device has been manufactured in accordance with the latest technological standards and approved safety regulations

The device should only be put into operation by trained and qualified staff. Care must be taken that all cable connections are laid and fixed in position correctly. The device should only be operated with the voltage supply indicated on the identification label.

The device should only be operated by qualified staff or employees who have received specific instruction.

If a device must be opened for repair, this should only be carried out by employees with appropriate qualifications or by **hopf** Elektronik GmbH.

Before a device is opened or a fuse is changed all power supplies must be disconnected.

If there are reasons to believe that the operational safety can no longer be guaranteed the device must be taken out of service and labelled accordingly.

The safety may be impaired when the device does not operate properly or if it is obviously damaged.

CE-Conformity



This device fulfils the requirements of the EU directive 89/336/EWG "Electromagnetic compatibility" and 73/23/EWG "Low voltage equipment".

Therefore the device bears the CE identification marking (CE=Communauté Européenne)

CE = Communautés Européennes = European communities

The CE indicates to the controlling bodies that the product complies with the requirements of the EU directive - especially with regard to protection of health and safety for the operator and the user - and may be released for sale within the common markets.

Contents	Page
1 General	7
2 Quick Install	9
3 Hardware	10
3.1 Front panel components	10
3.2 Installation	11
3.2.1 Power supply.....	11
3.2.2 Installation of the hopf Remote Software	11
3.3 Technical data	12
4 Software	15
4.1 Software system requirements for hopf Remote Software (HOPFRC.EXE)	15
4.2 Installation of the hopf Remote Software	15
4.2.1 Deinstallation of the hopf Remote Software.....	15
4.3 Commissioning the 4475 subsystem 4475 clock via hopf Remote Software	16
4.4 Operating the Remote Software.....	17
4.4.1 General	17
4.4.2 Starting hopf Remote Software	17
4.4.3 "File" Menu	18
4.4.4 "Controls" Menu	18
4.4.4.1 Menu Item "Time and Date"	19
4.4.4.2 Menu Item "Changeover Date"	20
4.4.4.3 Menu Item "Synchronization"	21
4.4.4.4 Menu Item "System Byte"	21
4.4.4.5 Menu Item "COM Redirection"	22
4.4.4.6 Menu Item "Reset Clock"	23
4.4.4.7 Menu Item "Firmware"	23
4.4.5 "Output" Menu	24
4.4.5.1 Menu Item "Allocate".....	24
4.4.5.2 Menu Item "COM".....	25
4.4.5.3 Menu Item "Optical Coupler".....	27
4.4.5.4 Menu Item "DCF77 Simulation"	29
4.4.5.5 Menu Item "IRIG-B"	30
4.4.5.6 IRIG Time Code Structure and Timing-Diagram	31
4.4.5.7 Format categories IRIG-Bxxx according to IRIG Standard 200-04	32
4.4.5.8 IRIG IEEE 1344-1995	32
4.4.5.9 AFNOR NFS 87-500.....	32
4.4.6 "Port" (PC-Interface) Menu	33
4.4.7 "Help" Menu	33
5 Data strings	34
5.1 hopf Standard String	34
5.1.1 Specified Settings	34
5.1.2 Structure.....	34
5.1.3 Status	35
5.1.4 Example	35

5.2	NTP (Network Time Protocol)	36
5.2.1	Specified Settings	36
5.2.2	Structure	36
5.2.3	Status	36
5.2.4	Example	36
5.3	hopf 2000 - 4 Digit Year Output	37
5.3.1	Specified Settings	37
5.3.2	Structure	37
5.3.3	Status	38
5.3.4	Example	38
5.4	Siemens SINEC H1	39
5.4.1	Specified Settings	39
5.4.2	Structure	39
5.4.3	Status	40
5.4.4	Example	40
5.5	T-String	41
5.5.1	Specified Settings	41
5.5.2	Structure	41
5.5.3	Status	41
5.5.4	Example	41
5.6	hopf Master/Slave-String	42
5.6.1	Specified Settings	42
5.6.2	Structure	43
5.6.3	Status	44
5.6.4	Example	44
5.7	GPS2000 Data String	45
5.7.1	Specified Settings	45
5.7.2	Structure	45
5.7.3	Example	45
5.8	SAT 1703 Time String	46
5.8.1	Specified Settings	46
5.8.2	Structure	46
5.8.3	Example	47
5.9	SINEC H1 Extended	48
5.9.1	Specified Settings	48
5.9.2	Structure	48
5.9.3	Example	49
6	Examples of connections	50
6.1	Assignment of the screw clips	50
6.1.1	Examples of connections for OC1-3	50
7	Glossary and abbreviations	52

1 General

The 4475 subsystem is a version of the 6875 GPS satellite radio-controlled clock without a GPS receiver and was designed for controlling industrial processes.

The synchronization of the 4475 subsystem is via a DCF77 pulse or a master/slave string via the serial interface input COM1 or COM2. The 4475 snap-in module for 35mm (DIN) track mounting is fitted with three **PhotoMOS signal relays**, an analogue output and up to four independent serial interfaces.

The PhotoMOS signal relay outputs can be used, for example, for controlling SPS or measuring processes. The following output modes are available:

- DCF77 pulse
- System status (remote-controlled or quartz)
- Status of the power supply in/out
- Cyclical pulses
- Non-cyclical pulses (1 pulse per day at a defined time, 1 pulse per year at a defined time on a defined date)

The analog output can be used for synchronizing **DCF77** or **IRIG-B** systems.

The serial interfaces **COM0...COM3** are used for the output of different pulses and strings. Each interface is configurable via **hopf** Remote Software "**HOPFRC.EXE**".

Other features of the snap-in module 4475 are:

- Potential-free antenna circuit
- All outputs are potential-free
- All parameter settings via the serial interface **COM0**
- The serial interface **COM1** can be switched from RS232 to RS422 via the configuration software
- One analog output **IRIG-B / DCF77-Out** which can be switched over via configuration software

The following versions are possible, as indicated on the identification label:

- FG447500 (Sub-Master DIN Rail Module 4475) with
 - 3 optical coupler pulse outputs
 - Serial interface 1: RS232 level
 - Serial interface 2: freely selectable in RS232/RS422/RS485 level
 - Logical outputs at the interfaces: **hopf** serial standard-strings, IRIG-B 00x, PPS-pulse, DCF77-pulse
 - Simulation output freely programmable: IRIG-B 12x or DCF77 antenna simulation (77.5kHz)
 - incl. CD and programming cable

- FG447503 (Sub-Master DIN Rail Module 4475) with
 - 1 fiber optic in- and output each
 - 3 optical coupler pulse outputs
 - Serial interface 1: RS232 level
 - Serial interface 2: freely selectable in RS232/RS422/RS485 level
 - Logical outputs at the interfaces: **hopf** serial standard-strings, IRIG-B 00x, PPS-pulse, DCF77-pulse
 - Simulation output freely programmable: IRIG-B 12x or DCF77 antenna simulation (77.5kHz)
 - incl. CD and programming cable

- FG447504 (Sub-Master DIN Rail Module 4475) with
 - 1 fiber optic input
 - 3 optical coupler pulse outputs
 - Serial interface 1: RS232 level
 - Serial interface 2: freely selectable in RS232/RS422/RS485 level
 - Logical outputs at the interfaces: **hopf** serial standard-strings, IRIG-B 00x, PPS-pulse, DCF77-pulse
 - Simulation output freely programmable: IRIG-B 12x or DCF77 antenna simulation (77.5kHz)
 - incl. CD and programming cable

The configuration software on the CD-ROM supplied is available for the most common MS Windows operating systems.

2 Quick Install

For the 4475 subsystem Quick Install the following steps must be carried out:

- Earth the equipment (see **chapter 3.2.1 Power supply**)
- Create a communication connection via interface cable between the PC and the radio-controlled clock
- Connect the power supply: +Vin, -Vin (18-72 VDC) – green LED flashes
- Install and start Remote Software (start **hopf** Remote Software with 9600 Baud, no parity, 8 bit word, 1 stop bit)
- Configure synchronization input (e.g.: COM3) and synchronization mode (e.g.: Master/Slave)
- Set the location-related time difference to UTC (local time - UTC) (only when synchronizing with DCF77 pulse)
- Connect to the synchronization source (e.g.: 6875 with optical output)
- Wait approx. 3-10 minutes until the radio-controlled clock is synchronized

The individual menu items of the program are explained on the following pages.

3 Hardware

3.1 Front panel components

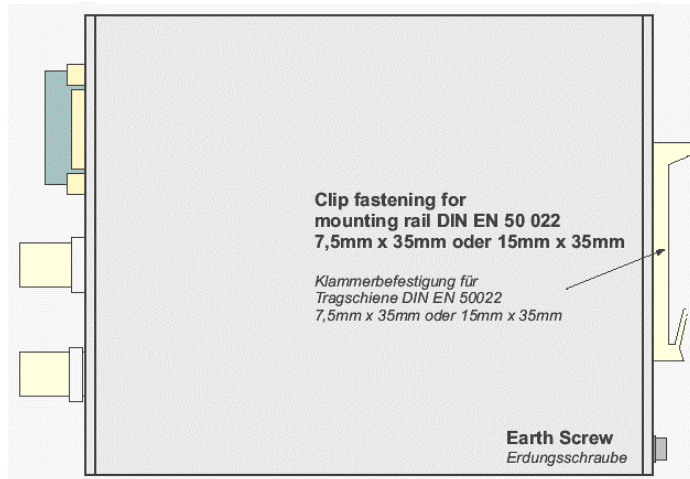
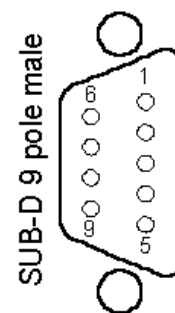

Photo 6875 – similar 4475

Connector X1	2 x 4-pole plug-in connectors (female with codeable profile and threaded flange (corresponding connector (male) included)		
+Vin	Connection for positive potential of the power supply		
-Vin	Connection for negative potential of the power supply		
+OC3, +OC2, +OC1	PhotoMOS signal relay connection for positive voltage potential (Drain)		
-OC3, -OC2, -OC1	PhotoMOS signal relay connection for negative voltage potential (Source)		
Connector X2	9-pole SUB-D male connector		
Pin No.:	Function		
1, 5	GND		
4	Digital output, TTL		
	COM0	RS232	
2	Receiving line	(RxD0)	
3	Transmission line	(TxD0)	
	COM1	RS232	RS422
6	Transmission line	TxD1	+TxD1 ¹
7	Transmission line		-TxD1 ²
8	Receiving line	RxD1	-RxD1 ²
9	Receiving line		+RxD1 ¹



¹ high active
² low active

LED / button	Function
CLK	LED green, indicates the synchronizations status of the clock
C1-C3	LED yellow, indicates the switch status of the corresponding PhotoMOS signal relay
DEF	Default button for restoring the standard configuration of the interfaces (9600, 8, N, 1)
BNC connectors	Function
IRIG-B / DCF77-Out	analog output for the output of the modulated IRIG-B or DCF77 signal (BNC connector)
Option	optical interfaces COM2, COM3 (ST connection: bayonet)
FL 1	optical transmitter for serial interface COM2
FL 2	optical transmitter COM3 / optical receiver for serial interface COM2

3.2 Installation

3.2.1 Power supply

The internal power supply of the 4475 DIN rail module has a potential-free structure. It must be earthed on the rear of the housing via the screw marked for this purposes in order to compensate the potential difference between the ground potential and the earth.

The power supply is connected via the 2 x 4-pole connector with the screw flange supplied (connections **+Vin** and **-Vin** on the plug-in connector X1). The system is supplied with a voltage of **18-72 V DC**.



Despite the internal protection against wrong poling, attention must be paid to the correct voltage level and polarity, when connecting the voltage. Commissioning may only be carried out by qualified staff.

3.2.2 Installation of the *hopf* Remote Software

See *chapter 4.2 Installation of the hopf Remote Software*.

3.3 Technical data

General	
Snap-in module dimensions of housing (WxHxD)	65 mm, 105 mm, 130 mm
Max. external dimensions (WxHxD)	65 mm, 105 mm, 155 mm
Environment Conditions	
Temperature: Operating:	0°C to +55°C
Storage:	-20°C to +75°C
Humidity:	max. 95%, not condensed
Power Supply	
	min. 18V to max. 72V DC
DC- decoupling	1500V DC
Typ. / max. performance	3,5 VA / 4 VA
MTBF	
	> 150.000 hrs.
Backup clock	
Accuracy:	± 25ppm at +10°C to +50°C
Buffering (maintenance free):	min. 3 / typ. 10 / max. 15 days
Optical coupler	
Max. performance, capacity in Ohms	60V DC / 200 mA
Switch on/off delay	130 / 70 µsec. at 10 mA switch mode power
DC- decoupling	500V DC
DCF77 pulse	
	output at COM1 , COM2 (FL1) , COM3 (FL2) , TTL (X2)
Accuracy	same as internal PPS pulse
Signal level	depending on output interface
DCF77 simulation output	
	output at BNC (IRIG-B / DCF77-Out)
Accuracy	same as internal PPS pulse
Carrier signal frequency	77.5 kHz ± 25 ppm
Signal level	3...5 mVpp at 50 Ohm

IRIG Time Code (general)	
Format	IRIG-B - B002 / B003 / B006 / B007, IEEE1344, AFNOR NFS 87-500
IRIG Time Code (digital)	
	output at COM1, COM2 (FL1), COM3 (FL2), TTL (X2)
Offset (to internal PPS pulse)	+440 μ sec ($< \pm 5 \mu$ sec)
Jitter / Stability	same as internal system accuracy
Signal level	depending on output interface
IRIG Time Code (analog)	
	output at BNC (IRIG-B / DCF77-Out)
Offset (to internal PPS pulse)	+440 μ sec ($< \pm 5 \mu$ sec)
Jitter / Stability	same as internal system accuracy
Carrier signal jitter (1kHz)	$\pm 2 \mu$ sec
Signal level	ca. 2 V _{pp} ($\pm 10\%$) at 50 Ohm ca. 2 V _{pp} ($\pm 10\%$) at 600 Ohm
Modulation ratio	3 : 1

Info: The IRIG-B Output is done by the **IRIG Standard 200-04!**

Interfaces:	COM0, COM1, COM2, COM3
Baud rate	300 - 19.200 Baud
Stop bit	1 / 2 Bit
Word length	7 / 8 Bit
Parity	no, even or odd
Miscellaneous	asynchronous, without handshake
Wire length	the wire length depends on the type of the cable and the adjusted baud rate.
Option:	optical interfaces
	Connection: ST series (bayonet)
Optical transmitter	COM2 (FL 1), COM3 (FL 2)
Optical receiver	COM2 (FL 2)
Wave length	$\lambda = 820 \text{ nm}$
Cable types supported (multimode)	50/125 μ m, 62.5/125 μ m, 100/140 μ m or 200 μ m HCS ® Fiber

Internal System Accuracy ⁽¹⁾

DCF77 Pulse	
DCF77 Pulse Signal Accuracy: < $\pm 300\text{nsec}$	
Accuracy ⁽²⁾ (absolute, to input signal)	< $\pm 300\text{ns}$
Jitter / Stability ⁽²⁾	< $\pm 1 * 10^{-7}$ ($\tau = 1\text{sec}$)
Free wheeling stability ⁽²⁾	< $\pm 1 * 10^{-7}$ (in the first 30 minutes, at constant temperature +10...+50 °C)
DCF77 Pulse Signal Accuracy: ca. $\pm 1,2\text{msec}$	
Accuracy ⁽²⁾ (absolute, to input signal)	< $\pm 5\mu\text{sec}$
Jitter / Stability ⁽²⁾ (averaged)	< $\pm 2 * 10^{-7}$ ($\tau = 1\text{sec}$)
Free wheeling stability ⁽²⁾	-

hopf Master/Slave String ⁽³⁾	
Accuracy ⁽²⁾ (absolute) (to the averaged input signal)	< $\pm 2\text{msec}$
Jitter / Stability ⁽²⁾ (averaged)	-
Free wheeling stability ⁽²⁾	-

General Quartz Frequency Characteristics	
Quartz frequency drift depending on Supply voltage changes	$\pm 2 * 10^{-10} / \text{V}$
Quartz frequency drift depending on temperature changes	$\pm 0,16 \text{ ppm}/^\circ\text{C}$ (at const. $U_{in}=24\text{V}$ and temperature radiation of approx $1,5^\circ\text{C}/\text{min}$)
Quartz aging	< $\pm 5 * 10^{-6} / \text{year}$

Comment:

- (1) The System-Quartz frequency is the leading dimension to generate a PPS pulse and an 1kHz (msec) and is deciding the system accuracy.
- (2) after a minimum of 4 hours continuously synchronization at const. temperature
- (3) Master/Slave String accuracy **ETX** at second change at 9600 Baud:
Offset: approx. +330 μsec (to GPS-PPS), Jitter: $\pm 60\mu\text{sec}$

τ : Acquisition time / averaging time

4 Software

4.1 Software system requirements for *hopf* Remote Software (HOPFRC.EXE)

The program requires a PC or Notebook with a free serial interface and the operating system Microsoft Windows from 95 or NT onwards.

4.2 Installation of the *hopf* Remote Software

Copy (or unzip) the data on the CD-ROM from the directory "**..\products\hopfrc**" into a directory on your PC..

The remote software is supported by Windows 95, 98, ME, NT, 2000 and XP.



The registries of the operating systems are **not** changed by the installation of the *hopf* Remote Software.

4.2.1 Deinstallation of the *hopf* Remote Software

The remote software can also be removed manually without any difficulty by deleting the appropriate data, links and directories.

4.3 Commissioning the 4475 subsystem 4475 clock via *hopf* Remote Software

The serial interface cable supplied is connected between the PC (at a free serial interface) and the subsystem 4475 (**COM0**).

Before starting the Remote Software for the first time the **remote.ini** should be checked. This is in the program directory created during installation.

The configurations file **remote.ini** sets the transmission parameters in the PC for communication with subsystem 4475 to e.g.: following values (standard):

- Baud rate: 9600 Baud
- Word length: 8 Bit
- Number of stop bits: 1
- Parity: NO

as well as indicating which serial PC interface (in the example: COM2) is assigned for communication with the radio-controlled clock.

The transmission settings for the serial PC interface must correspond to the transmission parameters of the serial interface **COM0** in the radio-controlled clock (in the example: delivery status). The delivery status can also be created by activating the **DEF** key.

When the parameters in the serial interface **COM0** of the radio-controlled clock are changed, then the settings in the serial interface of the PC must also be changed accordingly. This takes place automatically as long as the changes are made via remote software.

In order to ensure that the transmission parameters for the serial interface used are always available when the Remote Software is called up, they are saved in the configuration file **remote.ini**. For this reason **remote.ini** is always applied or updated when COM-Port parameters in the radio-controlled clock are changed.

If necessary, the **remote.ini** can also be edited manually. The settings must correspond to the values in the radio-controlled clock.

Structure of the file remote.ini	Interpretation of the variables
[serial parameters]	Section information
String=9600,N,8,1	Configuration of the transmission parameters (standard) <i>Baud rate, parity, word length, number of stop bits</i>
Port=com2	serial interface of PC (example: COM2)

4.4 Operating the Remote Software

4.4.1 General

The **hopf** Remote Software enables easy configuration of a **hopf** radio-controlled clock via an RS232 interface. All radio-controlled clock parameters can be displayed or set via a graphic user interface. These are divided into categories (file, controls outputs Port, help).

General menu functions:

Activating the button "**send**" effects the transmission of the values which are to be set to the radio-controlled clock. If there is a fault a message will be shown, otherwise the actual values will be updated.

This dialog is closed by clicking the "**exit**" button.

After the new settings of the radio-controlled clock have been received and evaluated, an updated string will be transmitted to the PC and in this way the dialog box is updated. If the transmission is successful a tick appears in the "**acknowledged**" check box. As soon as a slider or a check box is activated the remote software recognizes this as a change in the setting, then the tick in the "**acknowledged**" check box is deleted.

4.4.2 Starting **hopf** Remote Software

The remote software is accessed by double-clicking on the "**hopfrc.exe**" file in the corresponding directory or link, e.g. on the desktop.

On starting the programme checks whether the serial PC interface set is free. After this has been completed successfully the firmware and data of the radio-controlled clock are requested and displayed in the main window of the remote software (example in following illustration).

Among other details the transmission parameters of the serial PC interface are displayed.

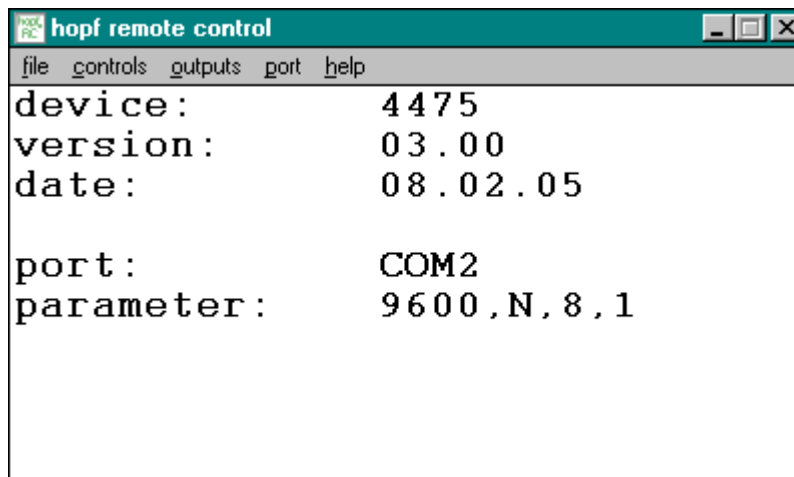

From this main menu all the functions of the 4475 subsystem can be set or/and displayed.

4.4.3 "File" Menu

The sub-menu "file" includes the following points:

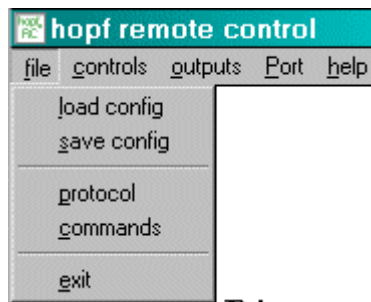

"**load config**" – load and save the total configuration from the remote-controlled clock. The file receives the ending *.dvp.

"**save config**" – load an existing *.dvp (total configuration) into the radio-controlled clock.

"**protocol**" and "**commands**" – tools for communication diagnosis..

"**exit**" – end remote software



After successful loading or saving of the total configuration from or into the radio-controlled clock "**data acknowledged**" appears in the bottom line in the main menu window.

4.4.4 "Controls" Menu

All the system functions of the remote-controlled clock are found under this menu item.

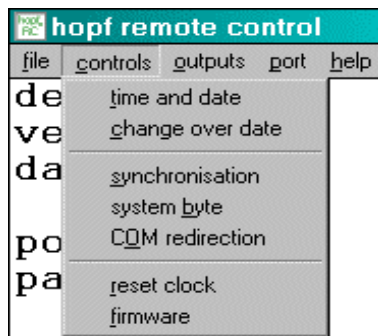

"**time and date**" – set or display time, date, weekday, time difference and timeout status

"**change over date**" – activate daylight-saving time and set or display changeover times

"**synchronization**" – display or set synchronization input and synchronization mode.

"**system byte**" – set or display system byte

"**COM redirection**" – configure pass-thru function (for interface in- and outputs)

"**reset clock**" – release a hardware reset of the radio-controlled clock

"**firmware**" – update and display firmware data of the radio-controlled clock

4.4.4.1 Menu Item "Time and Date"

Under this menu item the time, date, weekday, time difference and timeout status are set and displayed.

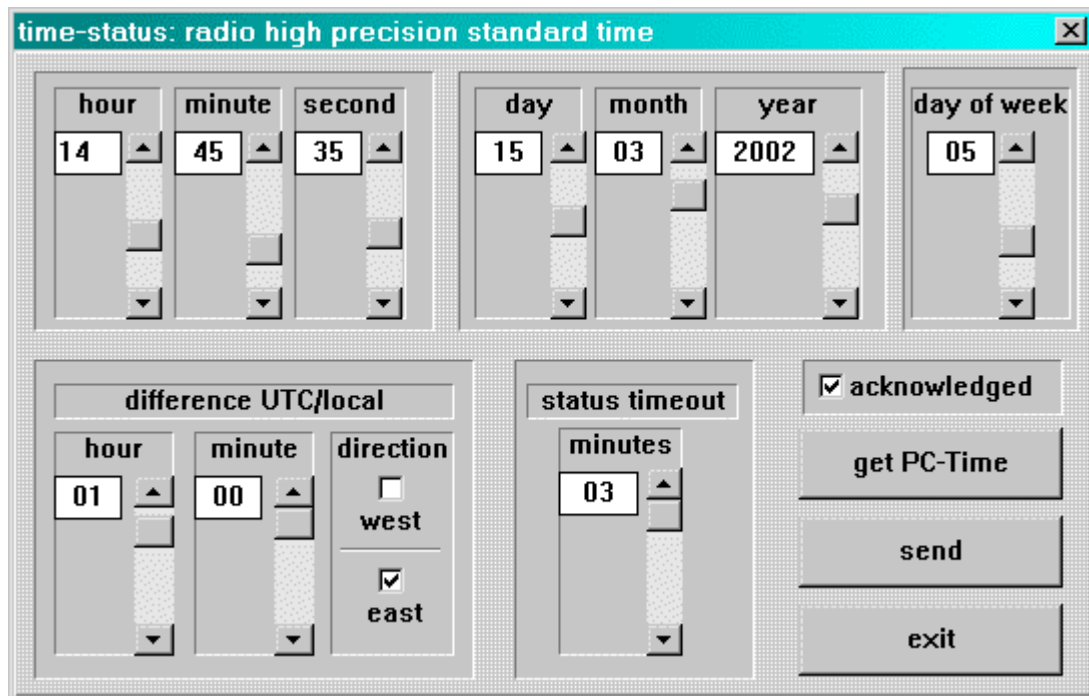

The time, the date and other variables in this dialog box are changed by moving the slider next to the appropriate display boxes.

When entering the time difference (between local time and world time [UTC time]) hours and minutes can be entering and information about the location to the west or to the east of the Greenwich meridian:

- e.g. **West 08:00** for the USA and Canada (Pacific Time)
- e.g. **East 01:00** for Germany

In the options window "**status timeout**" the resetting of the radio-controlled bit in time status can be delayed by increasing the duration of *timeout* (in minutes).

In the upper status bar of the "**time and date**" dialog window the current status of the clock is displayed. The clock status is for information purposes only and differs from synchronization status to time status and is defined as follows:

Synchronization status

- *crystal* – the radio-controlled clock is in quartz mode
- *radio precision* – the clock is in radio-controlled mode
- *radio high precision* – die clock is in radio-controlled mode with high accuracy

Time status

- *standard time* – local time is standard time (also winter time)
- *DST* – local time is summer time (also daylight saving time)
- *announce* – local time with notification of the switchover second or changeover time

4.4.4.2 Menu Item "Changeover Date"

Under this menu item the daylight saving / standard (summer / winter time) and the standard / daylight saving (winter / summer time) changeover times can be displayed and changed.

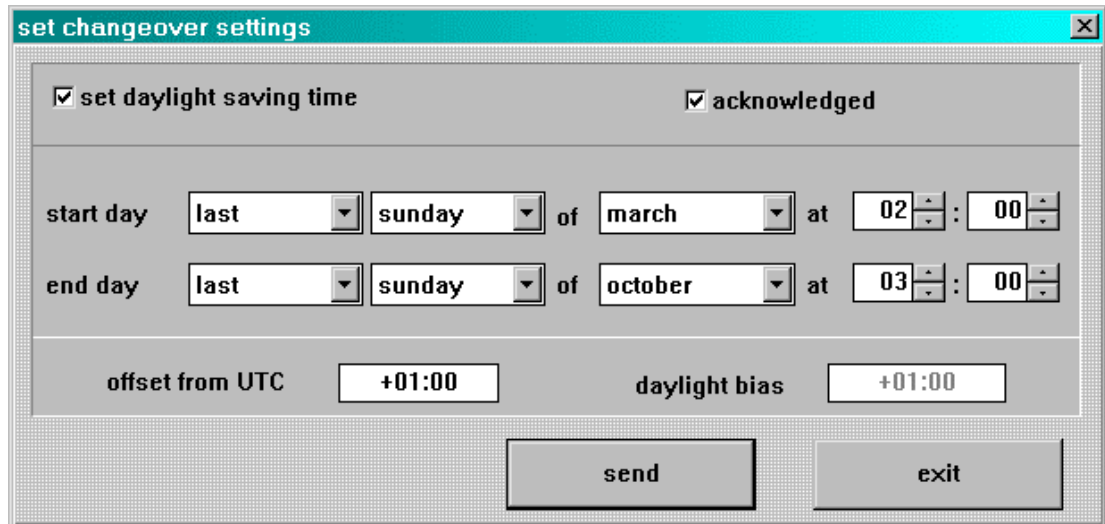

When this dialog window is called up the current settings can be read from the radio-controlled clock and displayed in the combo box. Here the times can be entered at which the changeover from daylight saving or winter time is to made at the location where the equipment is used.

In the line **start day** the starting time for daylight saving / summer time is indicated. The line **end day** indicates the point at which summertime ends.

The first, second, third, fourth or last weekday can be selected for the changeover. In addition the time must be stated in hours and minutes.

The changeover times can only be set if **set daylight saving time** is activated, otherwise the changeover times are set to zero and the radio-controlled clock operates with winter time (standard time).

The fields **offset from UTC** and **daylight bias** provide additional information about the current offset time.



If no changeover is required, then "set daylight saving time" should be deactivated and afterwards confirmed with "send". When synchronizing with DCF77 pulse or Master/Slave String, input of the changeover time is not necessary, since the current local time is taken from the time string.

4.4.4.3 Menu Item "Synchronization"

With this function the synchronization input and synchronization string are displayed or set.

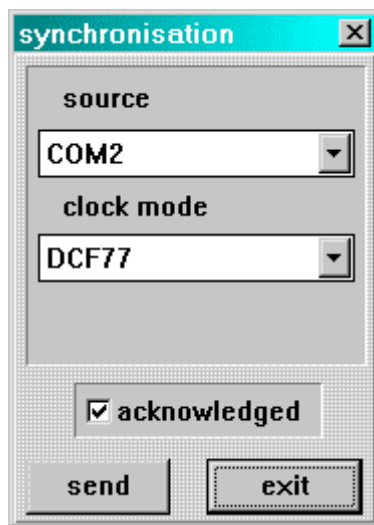

When this dialog window is called up the synchronization input which has been set is displayed in the dialog box "**source**" and in the dialog box "**clock mode**" the synchronization string is displayed.

At present the synchronization of the 4475 subsystem is only possible via **COM1** or **COM2** with **DCF77** pulse or **Master/Slave** string.

The synchronization via **analogue input** and **COM0** ("**source**" field) are not yet implemented. The 4475 subsystem operates in this modus as a quartz clock.

The 4475 subsystem can also be operated as a quartz clock. To do this "**quartz**" must be set in the dialog box "**clock mode**". The settings for synchronization input are not considered at this point.



When the 4475 subsystem is synchronized via the serial interface this is configured automatically until no further data output is possible.

4.4.4.4 Menu Item "System Byte"

With this function internal program functions are switched on or off.



Bit no.:	<u>set</u>	<u>not set</u>
0,1,2,3,4	unassigned	unassigned
5	release of changeover times in quartz mode	locking of changeover times in quartz mode
6	radio-controlled status always set	radio-controlled status only through synchronization
7	unassigned	unassigned



When the 4475 subsystem is synchronized via the serial interface or DCF77 pulse no changeover dates are required. These are taken from the synchronization string.

4.4.4.5 Menu Item "COM Redirection"

With this function the synchronization input can be transferred to an interface output. In this way unnecessary running times for further subsystems can be avoided.

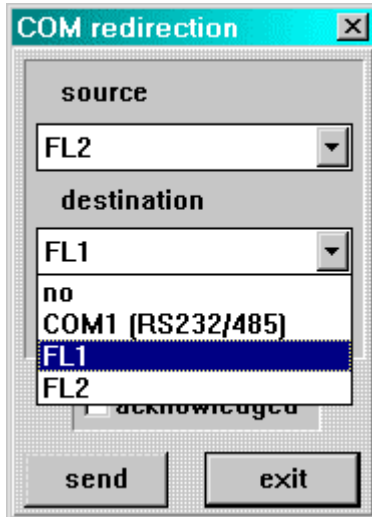

When this dialog window is called up the setting of the interface input is displayed and configured in the **"source"** dialog box and the setting of the interface output is displayed and configured in the **"destination"** dialog box.

The following synchronization interface inputs (the reception lines) can be selected as **"source"**:

- COM1
- COM2 (FL2)

The following interface outputs (transmission lines) can be selected as **"destination"**:

- COM1
- COM2 (FL1), in FG4475G01/2/3
- COM3 (FL2), in FG4475G02

If this function is not required it is advisable to deactivate this by selecting **"destination"** ⇔ **"no"**.

The interface setting in **"source"** is transferred direct to the interface setting in **"destination"** via the **"COM redirection" function**. The interface given in **"destination"** cannot be manipulated by the *hopf* software.



The use of this function does not change the interface configurations which have been set.

4.4.4.6 Menu Item "Reset Clock"

A restart of the clock is initiated by this function. The function does not change any of the settings made previously. A reset should be carried out after all entries of the required values have been made (time, time difference and position). In this way the initial synchronization can be accelerated.

Reset is activated via the menu item **"controls"** and the entry **"reset clock"**. After completion of reset the radio-controlled clock transmits a control string as confirmation. The following message appears:

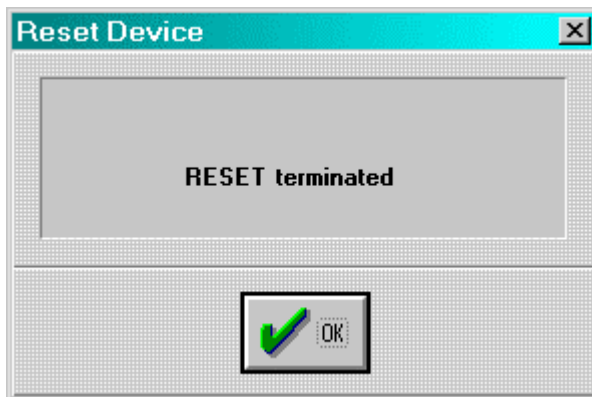

This menu item is closed by clicking the **OK** button, and then it is possible to edit further functions of the radio-controlled clock.



When changes have been made on the radio-controlled clock the minute change must be awaited before starting reset.

4.4.4.7 Menu Item "Firmware"

Firmware data can be accessed and updated via the menu item **"controls"** and entering **"firmware"**. This information then appears in the main menu window and is for information purposes.

4.4.5 "Output" Menu

All the inputs and outputs of the radio-controlled clock can be configured from this menu.

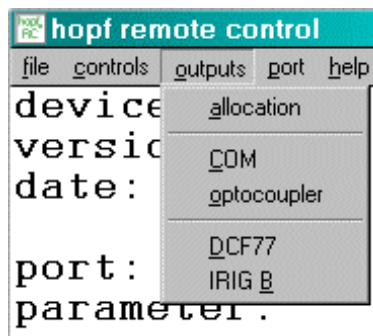

- "allocation" – shunting the outputs
- "COM" – configuration of the serial interfaces
- "optocoupler" – configuration of the PhotoMOS signal relays
- "DCF77" – configuration of the DCF77 simulation
- "IRIG-B" – configuration of IRIG-B

On selecting the respective menu item the corresponding menu dialog is started.

4.4.5.1 Menu Item "Allocate"

In this dialog window the outputs of the radio-controlled clock can be shunted.

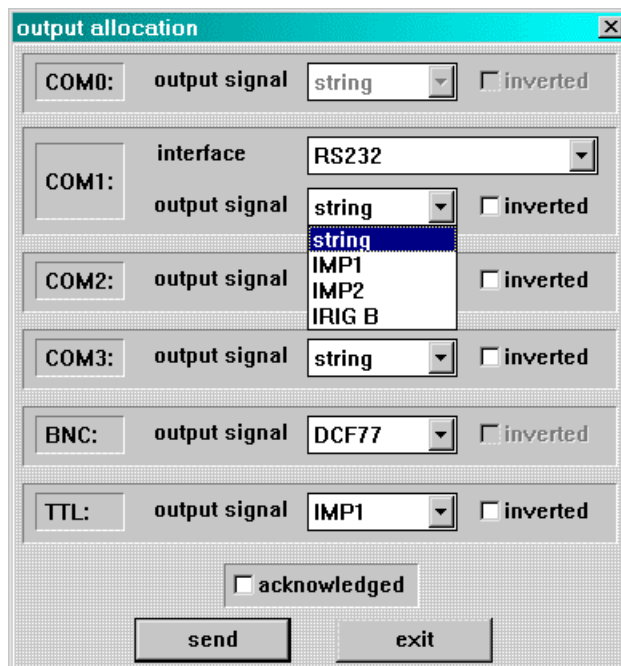

The functions in the **COM0** dialog box (serial interface **COM0** in the radio-controlled clock) are deactivated, modification is not possible here. There are three functions in the dialog box **COM1** (serial interface **COM1** in the radio-controlled clock).

- with the **interface** function it is possible to select between **RS232**, **RS422 full-duplex**. In this way the serial interface COM1 can be shunted as RS232 or RS422.
- with the **output signal** function the output of the serial interface COM can be shunted between **string** (output of data strings), **IMP1** and **IMP2**, **IRIG-B** pulse.
- with the function **inverted** the COM1 interface output can be inverted.

In the dialog boxes **COM2** and **COM3** (serial interface **COM2** and **COM3** in the radio-controlled clock) there are two functions:

- with the **output signal** function the output of the corresponding serial interface can be shunted between **string** (output of data strings), **IMP1** and **IMP2**, **IRIG-B** pulse.
- with the function **inverted** the corresponding interface output can be inverted.

The dialog box **BNC** refers to the analogue **IRIG-B/DCF-Sim** output in the radio-controlled clock and includes one function:

- with the **output signal** function the analogue output can be shunted between **DCF77** simulation or **IRIG-B** signal generation.

In the dialog box **TTL** (digital **TTL** output in the radio-controlled clock) there are two functions:

- with the **output signal** function the output of the corresponding serial interface can be shunted between **IMP1** and **IMP2**, **IRIG-B** pulse.
- with the function **inverted** the corresponding interface output can be inverted.



The configuration of **IMP1** (pulse1) and **IMP2** (pulse2) is in the "optical coupler" menu.

4.4.5.2 Menu Item "COM"

In this menu item the transmission parameters and the output of the data strings of the serial interfaces of the radio-controlled clock can be configured..

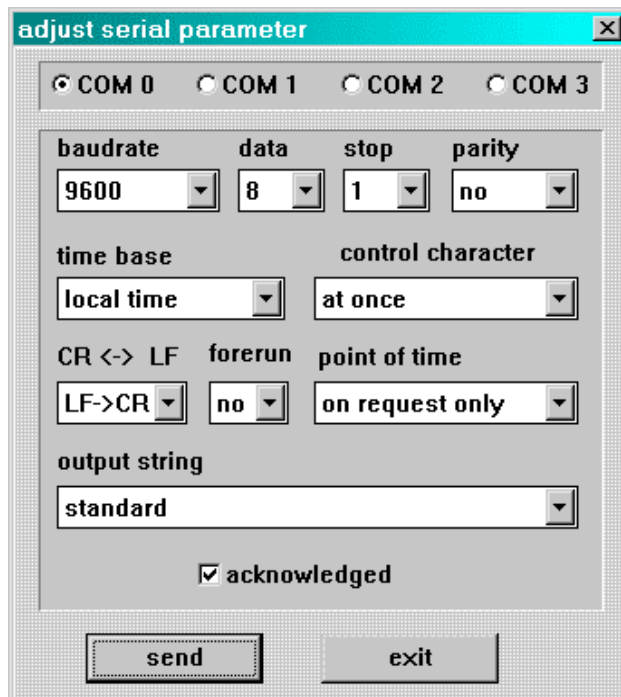

The dialog box and the methods of input are the same for each interface. To configure an interface e.g.: **COM0**, this must be selected using the selection button. The configuration data for this interface are requested by the radio-controlled clock and displayed in the dialog window.

When the combo box or the register button is clicked in the parameter box a table with a selection of possible settings appears.

Parameter boxes

Baud rate	input of the Baud rate: between 150, 300, 600, 1200, 2400, 4800, 9600 and 19200 Baud
Data	input of the word length: 8 or 7 Bit
Stop	number of stop bits: 1 or 2
Parity	input of the parity: no , odd , even
Time basis	time basis for the data string: local time or UTC
Control character	output of ETX in the data string: at once (ETX together with the data string), on second change (ETX at the second change) or with string delay (ETX at the second change with Baud rate delay)
CR <-> LF	sequence for CR and LF: CR->LF or LF->CR
Forerun	output of the data string with forerun: no , 1s (with 1 second forerun)
Point of time	output of the data string: on second change , on minute change , on hour change , on request only
Output string	The following Data Strings can be given out: <ul style="list-style-type: none"> • hopf Standard (6021) • hopf 2000 – 4 Digit Year Output • hopf Master/Slave-String • SINEC H1 • T-String • GPS2000 • SAT 1703 Time String • SINEC H1 Extended

4.4.5.3 Menu Item "Optical Coupler"

From this dialog window it is possible to configure up to three PhotoMOS signal relay outputs and both pulse options.

This dialog window has an interactive structure, i.e. the dialog box appears or fades according to the activated mode. So only the parameters required for the corresponding mode are set or changed.

On clicking the check box for **OC1..3** and **IMP1..2** at the top of the dialog window on the left the current settings for the corresponding PhotoMOS signal relay output appear.

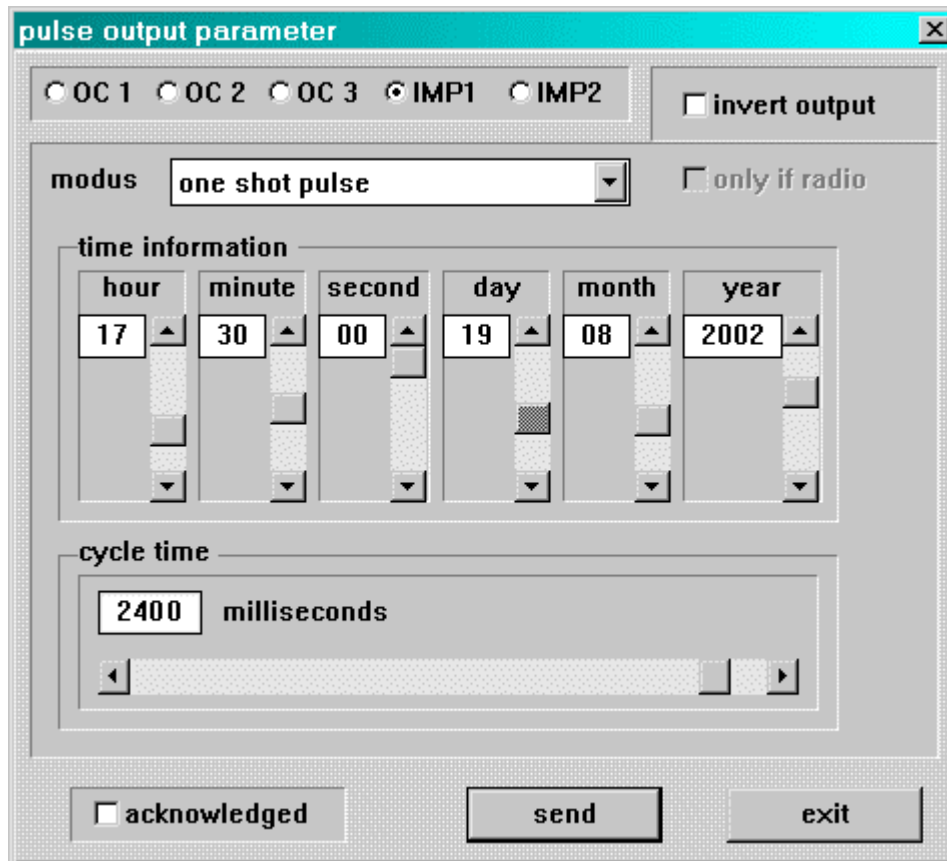

The individual functions are called modes and are selected in the dialog box "modus".

DCF77 pulse (Mode 0)

The time information is provided in a data string as a DCF77 pulse at the corresponding PhotoMOS signal relay. This setting is used e.g. for synchronizing further DCF77 radio-controlled clocks with 1 Hz pulse input such as **hopf** 6036. If required the signal can be emitted inversely. The settings for the DCF77 pulse are made in the DCF77 menu and are valid for all outputs which emit this pulse.

Radio status: Information on synchronization (Mode 1)

In this setting the internal clock status (radio-controlled bit) is emitted at the output. If the PhotoMOS signal relay is switched through, then the clock is in radio-controlled mode. A lapsing of the signal indicates quartz mode. The signal output cannot be inverted.

Power on: alarm message (Mode 2)

In this operating mode the output switched through when the power supply is connected. If the power supply fails the signal lapses and thereby indicates alarm. The signal output cannot be inverted.

Periodic pulse: cyclical pulse within 24 hours (Mode 3)

In this mode cyclical pulses with adjustable pulse width are generated at the PhotoMOS signal relay output. Following pulse intervals are possible:

every 1, 2, 3, 4, 6, 8, 12, 24 hours

every 1, 2, 3, 4, 5, 6, 10, 12, 15, 20, 30 minutes

every 1, 2, 3, 4, 5, 6, 10, 12, 15, 20, 30 seconds

The output time of the pulse is set with the sliders in the option "**time information**".

For setting the 24-hour pulse a zero must be entered in the options "**time information**" at all data positions.

The entries for day, month and year are deactivated. The pulse length can be selected in the range **10-2550 msec** in **10 msec** steps.

The pulse duration should not exceed the cycle time, otherwise the output is switched through permanently. The signal output cannot be inverted.

Daily pulse: pulse per day (Mode 4)

This mode generates one single pulse per day at a defined point in time. The output time of the pulse is set with the slider in the option "**time information**".

The pulse length can be selected in the range **0-2550 msec** in **10 msec** steps. The signal output cannot be inverted.

One shot pulse: pulse per time and date (Mode 5)

This mode generates one single pulse at the output per time and date. Time and date of the pulse are set with the slider in the option "**time information**".

The pulse length can be selected in the range **10-2550 msec** in **10 msec** steps. The signal output can be inverted.

Depending on the function (mode) selected time information can be set in the options window "**time information**" and switching duration in the window "**cycle time**". If no provision is made for a time setting in the selected mode the corresponding input fields are deactivated. By activating the check box "output inverted" the PhotoMOS signal relay can be operated inversely in modes 1,4 and 5.

The "**output inverted**" is of no benefit in modes 2 and 3 since, in case of power failure, false information would be passed on to the outputs. In the following sections there follows a detailed description of each of the modes.

By activating the check box "**only if radio**" it is possible to bind the pulses specifically for **IMP 1** and **IMP 2** to the radio-controlled clock status in modes 3 and 4, i.e. the pulse output is only possible when the radio-controlled clock is in radio mode. Configuration for the inverted output of the pulses **IMP 1** and **IMP** is described in the section "**allocate**" in **chapter 4.4.5.1 Menu Item "Allocate"**.

The settings for the individual PhotoMOS signal relays are each transmitted individually to the radio-controlled clock.

4.4.5.4 Menu Item "DCF77 Simulation"

In this menu item the settings for DCF77 simulation or DCF77 pulse are made. These are global settings and are valid for all DCF77 simulation or DCF77 pulse outputs. The following settings are possible:

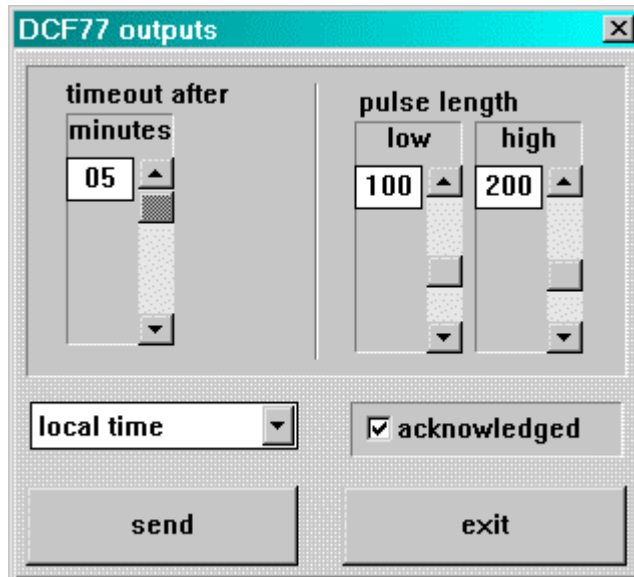

In the options window "**pulse length**" the lengths for high and low pulse time of the DCF77 simulation are selected. With the scrollbar "**time out after xx minutes**" the output of the simulation can be switched off after the time set (2 – 254 minutes) when changing into quartz mode.

If the value is set to 255 the simulation is not switched off. These settings have an effect on the DCF77 antenna simulation via the BNC connector in the front panel and on any DCF77 simulation in the optical couplers and on the status LED in the front panel.

It is possible to delay the switching off of DCF77 simulation and radio-controlled bit. This serves to compensate any breaks in reception when the clock module 4475 would not fall below the required accuracy as a result of its internal control.

Example:

If an accuracy greater than 1 msec is required, the second pulse generated at the output should not deviate by more than ± 1 msec from the absolute time marker. This value would be reached at a maximal quartz drift (0,1 ppm) in freewheeling status after $1000/0,1 = 10,000$ seconds. Signalization of quartz mode would therefore only be necessary after 166minutes.

4.4.5.5 Menu Item "IRIG-B"

In this section the settings for the IRIG Time Code signal generation (analogue) are made.

These are global settings and are valid for the output of the analogous amplitude modulated signal (e.g. IRIG-B B12x) as well as for the digital pulse width modulated signal (e.g. IRIG-B B00x).

The 'analogue' IRIG Time Code is given out at the BNC-connector (IRIG-B). The outputs for IRIG Time Code (digital) can be configured as described in **chapter 4.4.5 "Output" Menu**.

IRIG Time Code Formats

The following formats of IRIG Time Code are available:

- IRIG-B - B002/B122 (time)
- IRIG-B - B003/B123 (time, seconds of day)
- IRIG-B - B006/B126 (time, year)
- IRIG-B - B007/B127 (time, year, seconds of day)
- IEEE1344
- AFNOR NFS 87-500

Info: The IRIG-B output is done by the **IRIG Standard 200-04**.

Time Base for IRIG Time Code

For special applications the time basis transmitted in the IRIG Time Code can be configured.

- Local Time
- UTC Time

IRIG Time Code Timeout for delayed Output Break

The value for **IRIG Time Code Timeout** can be set between **002** and **255** minutes. This value acts as temporarily limited output of the IRIG Time Code after loss of synchronisation to quartz status 'C'.



In case of **IRIG Time Code Timeout = 255** minutes the output of the IRIG Time Code is done as early as the system has a valid (system) time.

4.4.5.6 IRIG Time Code Structure and Timing-Diagram

The IRIG format consists of one time code with 74 bits and has a repeatability rate of one second. The bit frame is 10 msec. The rating of a bit is displayed by a pulse width modulation and is shown in multiples of a millisecond.

With analogue output the positive zero cycle of a sine oscillation (carrier frequency 1000Hz) is modulated with the rising edge of the IRIG signal. The rate of modulation for the signal information of H/L level should be between 3:1 and 6:1. The Din-Rail Module 4475 distributes a modulation of 3:1.

To synchronize to the beginning of a second a neutral logic status is required which is called the identifier.

Logic 0 = 2 msec H-level
 Logic 1 = 5 msec H-level
 Identifier = 8 msec H-level

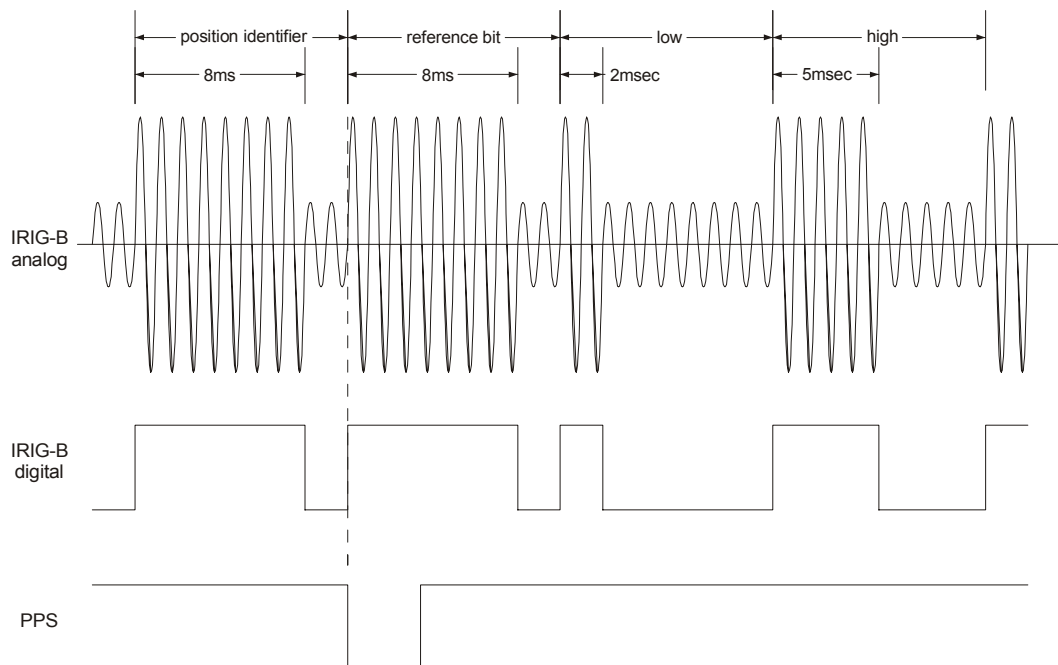

The 74 time code bits are divided into

- 30 bits for the BCD value of seconds, minutes, hours and the current day of year
- 27 bits for the input of control information
- 17 bits for the binary value of the current seconds of day

100 bit frames can be transmitted in one second. Unused bit frames are filled with a logical zero.

4.4.5.7 Format categories IRIG-Bxxx according to IRIG Standard 200-04

Signal output can be digital or analogue and also with different data content. The variations are indicated by attaching a three-digit combination of figures.

The figures have the following meaning:

Figure 1	0	= digital output
	1	= analogue output via carrier
Figure 2	0	= no carrier
	1	= carrier 100 Hz
	2	= carrier 1000 Hz
Figure 3	0	= time, second of day, control information
	1	= time, control information
	2	= time
	3	= time, second of day
	4	= time, year, second of day, control information
	5	= time, year, control information
	6	= time, year
	7	= time, year, second of day

e.g. **IRIG-B123** = analogue output, carrier 1000 Hz,
= data content time information and binary seconds of day

4.4.5.8 IRIG IEEE 1344-1995

This IRIG standard is based on IRIG Standard 200-89. Fixed data such as year, time offset etc. are assigned to the 27 bits of the control information field.

The IRIG Standard 200-89 is contained as subset in the IEEE1344.

4.4.5.9 AFNOR NFS 87-500

The AFNOR NFS 87-500 Code is similar to the IRIG Time Code Standard. It has been laid down by the French institute for standards and is based on the IRIG Standard 200-04.

The IRIG-B Standard 200-89 is contained as subset in the AFNOR NFS 87-500.

4.4.6 "Port" (PC-Interface) Menu

In this menu dialog it is possible to start configuration of the **PC-Interface** which is used by the remote software for communication with the radio-controlled clock.

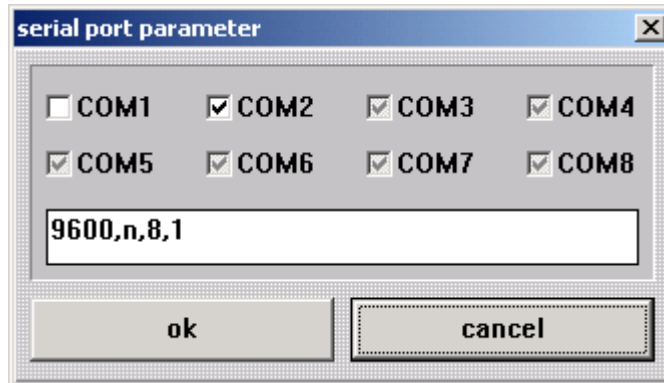

The serial interfaces which are assigned to other programs or are not available are recognized by the Remote Software and displayed as not available for selection (background of checkbox is grey). By activating the corresponding **COMx** check box the free serial interface (background of check box is white) can be selected.

The interface parameters for Baud rate, parity, data bits and stop bits are entered into the dialog box, each separated by a comma. For standard setting see the above illustration.

The 4475 can be reset to standard interface parameters by holding down the DEF button in the front panel for 10 seconds.

4.4.7 "Help" Menu

Under "**about**" in this menu you will find information about the status of programmes for 4475 Remote Software and contacts at **hopf** Elektronik GmbH.

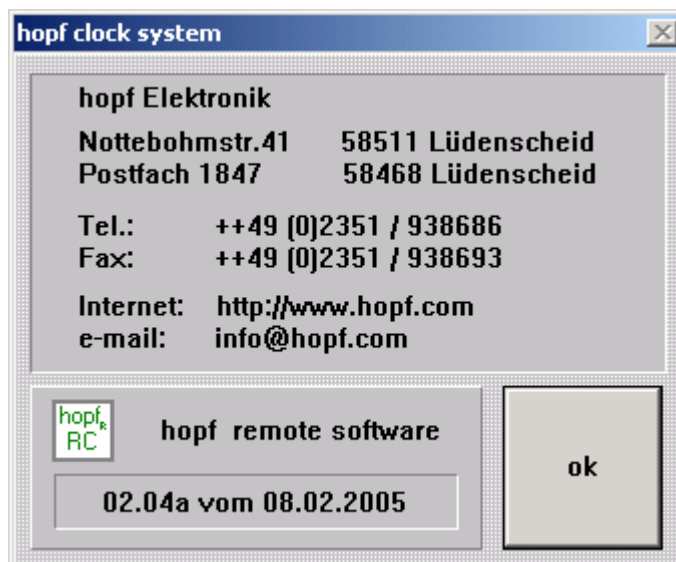

5 Data strings

General information on the serial data output of the 4475 board

When setting ETX on the second change a transmission gap occurs, depending on the Baud rate, of up to 970 msec. Please pay attention to this when programming timeout on the receiving side.

On all data strings the output of control character CR and LF can be exchanged with a **modebyte**.

The transmitted data string are compatible with the data strings of the following **hopf** clocks:

- Board 6020/6021 standard with control character
- Board 7200/7201 standard with control character
- Board 7220/7221 standard with control character
- Board 7240/7245 standard with control character
- Board 6840/6841 standard with control character
- System 4465 standard with control character
- System 6870 standard with control character

5.1 **hopf** Standard String

5.1.1 Specified Settings

No specified settings for this data string are necessary.

5.1.2 Structure

Character No.	Meaning	Hex-Value
1	STX (start of text)	\$02
2	status (internal clock status)	\$30-39, \$41-46
3	day of the week (1=Monday ... 7=Sunday) for UTC time bit 3 is set to 1 in the day of the week	\$31-37
4	tens hour	\$30-32
5	unit hour	\$30-39
6	tens minute	\$30-35
7	unit minute	\$30-39
8	tens second	\$30-36
9	unit second	\$30-39
10	tens day	\$30-33
11	unit day	\$30-39
12	tens month	\$30-31
13	unit month	\$30-39
14	tens year	\$30-39
15	unit year	\$30-39
16	LF (line feed)	\$0A
17	CR (carriage return)	\$0D
18	ETX (end of text)	\$03

5.1.3 Status

The second and the third ASCII-character contain the status and the day of the week. The status is decoded binary.

	b3	b2	b1	b0	Meaning
Status:	x	x	x	0	no announcement hour
	x	x	x	1	announcement(ST-WT-ST)
	x	x	0	x	standard time (WT)
	x	x	1	x	daylight saving time (ST)
	0	0	x	x	time / date invalid
	0	1	x	x	crystal operation
	1	0	x	x	radio operation
	1	1	x	x	radio operation (high accuracy)
Day of the Week:	0	x	x	x	CEST / CET
	1	x	x	x	UTC - time
	x	0	0	1	Monday
	x	0	1	0	Tuesday
	x	0	1	1	Wednesday
	x	1	0	0	Thursday
	x	1	0	1	Friday
	x	1	1	0	Saturday
	x	1	1	1	Sunday

Status Byte	Meaning		
0-3	time invalid		
4 = 0100	crystal operation	winter	no announcem. ST-WT-ST
5 = 0101	crystal operation	winter	announcem. ST-WT-ST
6 = 0110	crystal operation	summer	no announcem. ST-WT-ST
7 = 0111	crystal operation	summer	announcem. ST-WT-ST
5 = 0101	radio operation	winter	no announcem. ST-WT-ST
6 = 0110	radio operation	winter	announcem. ST-WT-ST
7 = 0111	radio operation	summer	no announcem. ST-WT-ST
8 = 1000	radio operation	summer	announcem. ST-WT-ST
C = 1100	radio operation with quartz adj.	winter	no announcem. ST-WT-ST
D = 1101	radio operation with quartz adj.	winter	announcem. ST-WT-ST
E = 1110	radio operation with quartz adj.	summer	no announcem. ST-WT-ST
F = 1111	radio operation with quartz adj.	summer	announcem. ST-WT-ST

5.1.4 Example

(STX)E3123456061102(LF)(CR)(ETX)

- It is Wednesday 06.11.02 - 12:34:56 o'clock.
- radio operation (high accuracy)
- daylight saving time
- no announcement
- () - ASCII-control characters e.g. (STX)

5.2 NTP (Network Time Protocol)

NTP or also xNTP is a batch of programmes to synchronise different computers and operating systems with network support. It is the standard for the Internet Protokoll TCP/IP (RFC-1305). Source code and documentation are available as freeware in the internet under the following address:

<http://www.ntp.org>

Binaries for the IBM Operating System AIX are available at the **hopf** Internet site::

<http://www.hopf.com>

There are already pre-configured NTP packages for **hopf** radio-controlled clocks with serial interface. On the homepage of Ruprecht & Partner (OEG) (<http://www.rdcs.at/>) these are available for downloading for the following operating systems:

- RedHat Linux 7.1, SuSE Linux 7.2, Solaris 8 (SPARC)

5.2.1 Specified Settings

parameter of transmission:

- baud rate 9600
- 8 data bit
- parity no
- 1 stop bit

mode of transmission:

- **hopf** Standard String, UTC as time base
- second in advance = on, control character (STX...ETX) enabled
- with ETX as On Time Mark
- Output time and date, output every second

5.2.2 Structure

NTP is according to the **hopf** Standard String (see **Chapter 5.1**).

5.2.3 Status

The Status is according to the **hopf** Standard String (see **Chapter 0**).

5.2.4 Example

(STX)EB123456061102(LF)(CR)(ETX)

- It is Wednesday 06.11.2002 - 12:34:56 o'clock.
- radio operation (high accuracy)
- UTC
- no announcement for ST/WT change over (nonexistent in case of UTC)
- () - ASCII control character e.g. (STX)

5.3 **hopf2000 - 4 Digit Year Output**

Below the data string **hopf2000 - 4 Digit Year Output** is described.

5.3.1 Specified Settings

No specified settings for this data string are necessary.

5.3.2 Structure

Character No.	Meaning	Hex-Value
1	STX (start of text)	\$02
2	status (internal clock status)	\$30-39, \$41-46
3	day of the week (1=Monday ... 7=Sunday) for UTC time bit 3 is set to 1 in the day of the week	\$31-37
4	tens hour	\$30-32
5	unit hour	\$30-39
6	tens minute	\$30-35
7	unit minute	\$30-39
8	tens second	\$30-36
9	unit second	\$30-39
10	tens day	\$30-33
11	unit day	\$30-39
12	tens month	\$30-31
13	unit month	\$30-39
14	thousandths year	\$31-32
15	hundreds year	\$30, \$39
16	tens year tens digit	\$30-39
17	unit year unit digit	\$30-39
18	LF (line feed)	\$0A
19	CR (carriage return)	\$0D
20	ETX (end of text)	\$03

5.3.3 Status

The second and the third ASCII-character contain the status and the day of the week. The status is decoded binary. Structure of these characters :

	b3	b2	b1	b0	Meaning
Status:	x	x	x	0	no announcement hour
	x	x	x	1	announcement (ST-WT-ST)
	x	x	0	x	standard time (WT)
	x	x	1	x	daylight saving time (ST)
	0	0	x	x	time / date invalid
	0	1	x	x	crystal operation
	1	0	x	x	radio operation
	1	1	x	x	radio operation (high accuracy)
Day of the Week:	0	x	x	x	CEST / CET
	1	x	x	x	UTC - time
	x	0	0	1	Monday
	x	0	1	0	Tuesday
	x	0	1	1	Wednesday
	x	1	0	0	Thursday
	x	1	0	1	Friday
	x	1	1	0	Saturday
	x	1	1	1	Sunday

5.3.4 Example

(STX)E312345603011996(LF)(CR)(ETX)

- It is Wednesday 03.01.1996 - 12:34:56 o'clock
- radio operation (high accuracy)
- daylight saving time
- no announcement
- () - ASCII-control characters e.g. (STX)

5.4 Siemens SINEC H1

Below the data string Siemens SINEC H1 is described.

String request

The data string SINEC H1 can also send by request. The time of output will be set to "send only by request" and the string will be requested with the ASCII character "?".

5.4.1 Specified Settings

No specified settings for this data string are necessary.

5.4.2 Structure

Character No.	Meaning	Hex-Value
1	STX (start of text)	\$02
2	"D" ASCII D	\$44
3	":" colon	\$3A
4	tens day	\$30-33
5	unit day	\$30-39
6	"." point	\$2E
7	tens month	\$30-31
8	unit month	\$30-39
9	"." point	\$2E
10	tens year	\$30-39
11	unit year	\$30-39
12	"," semicolon	\$3B
13	"T" ASCII T	\$54
14	":" colon	\$3A
15	day of the week	\$31-37
16	"," semicolon	\$3B
17	"U" ASCII U	\$55
18	":" colon	\$3A
19	tens hour	\$30-32
20	unit hour	\$30-39
21	"." point	\$2E
22	tens minute	\$30-35
23	unit minutes	\$30-39
24	"." point	\$2E
25	tens second	\$30-36
26	unit second	\$30-39
27	"," semicolon	\$3B
28	"#" or space	\$23 / \$20
29	"*" or space	\$2A / \$20
30	"S" or space	\$53 / \$20
31	!" or space	\$21 / \$20
32	ETX (end of text)	\$03

5.4.3 Status

The characters 28 - 31 in the data string SINEC H1 tell the synchronisation status of the clock.

The characters mean the following:

character no. 28 = "#"	no radio synchronisation after reset, time invalid
space	radio synchronisation after reset, clock in crystal operation

character no. 29 = "**"	time from internal crystal in the clock
space	time by radio reception

character no. 30 = "S"	daylight saving time
space	standard time

character no. 31 = "!"	announcement of a W/S or S/W change over
space	no announcement

5.4.4 Example

(STX)D:06.11.02;T:3;U:12.34.56; _ _ _ _ (ETX) (_) = Space

- It is Wednesday 06.11.02 - 12:34:56 o'clock
- radio operation
- standard time
- no announcement ST/WT change over

5.5 T-String

The T-string can be transmitted with all modes (e.g. with forerun or final character at the second change).

The data string can be requested with "T".

5.5.1 Specified Settings

No specified settings for this data string are necessary.

5.5.2 Structure

Character No.	Meaning	Hex-Value
1	"T" ASCII T	\$54
2	":" colon	\$3A
3	tens year	\$30-39
4	unit year	\$30-39
5	":" colon	\$3A
6	tens month	\$30-31
7	unit month	\$30-39
8	":" colon	\$3A
9	tens day	\$30-33
10	unit day	\$30-39
11	":" colon	\$3A
12	tens day of the week	\$30
13	unit day of the week	\$31-37
14	":" colon	\$3A
15	tens hour	\$30-32
16	unit hour	\$30-39
17	":" colon	\$3A
18	tens minute	\$30-35
19	unit minute	\$30-39
20	":" colon	\$3A
21	tens second	\$30-36
22	unit second	\$30-39
23	CR (carriage return)	\$0D
24	LF (line feed)	\$0A

5.5.3 Status

No status contained in the T-String.

5.5.4 Example

T:02:11:06:03:12:34:56(CR)(LF)

It is Wednesday 06.11.02 - 12:34:56 o'clock

5.6 **hopf** Master/Slave-String

The **hopf** Master/Slave-String can be used to synchronise slave systems with the time data of the master system up to an accuracy of ± 0.5 msec. It differs from the **hopf** DCF77-slave-string in as much as the UTC time is included in the transmission.

The **hopf** Master/Slave-String transmits:

- the full time information (hour, minute, second),
- the date (day, month, year [2 digits]),
- the difference time local to UTC (hour, minute),
- the day of the week,
- and status information (announcement of ST/WT change over, announcement of a leap second and the status of reception of the Master/Slave-String source).

5.6.1 Specified Settings

The following settings are required for the synchronisation of the **hopf** slave-systems:

- output every minute
- output second forerun
- ETX on the second change; selectable: data string at the beginning or at the end of the 59. second.
- local time
- 9600 baud, 8 bit, 1 stop bit, no parity

This setting guarantees the best control of the time basis in the slave systems.



In case of Master/Slave-String these settings are fixed automatically.
Furthermore the according parameter byte shows the last chosen settings.

5.6.2 Structure

Character No.	Meaning	Hex-Value
1	STX (start of text)	\$02
2	status	\$30-39, \$41-46
3	day of the week	\$31-37
4	tens hour	\$30-32
5	unit hour	\$30-39
6	tens minute	\$30-35
7	unit minute	\$30-39
8	tens second	\$30-36
9	unit second	\$30-39
10	tens day	\$30-33
11	unit day	\$30-39
12	tens month	\$30-31
13	unit month	\$30-39
14	tens year	\$30-39
15	unit year	\$30-39
16	difference time tens hour / operational sign	\$30-31, \$38-39
17	difference time unit hour	\$30-39
18	difference time tens minutes	\$30-35
19	difference time unit minutes	\$30-39
20	LF (line feed)	\$0A
21	CR (carriage Return)	\$0D
22	ETX (end of text)	\$03

The difference time is transmitted in hours and minutes following the year. The transmission is done in BCD. The difference time may be up to ± 11.59 h.

The operational sign is shown as the highest bit in the hours.

logic **1** = local time before UTC

logic **0** = local time after UTC

Example:

Data String	Tens Difference Time	Difference Time
(STX)83123456030196 <u>0</u> 300(LF)(CR)(ETX)	<u>0000</u>	- 03:00h
(STX)83123456030196 <u>1</u> 100(LF)(CR)(ETX)	<u>0001</u>	- 11:00h
(STX)83123456030196 <u>8</u> 230(LF)(CR)(ETX)	<u>1000</u>	+ 02:30h
(STX)83123456030196 <u>9</u> 100(LF)(CR)(ETX)	<u>1001</u>	+ 11:00h

5.6.3 Status

	b3	b2	b1	b0	Meaning
Status:	x	x	x	0	no announcement hour
	x	x	x	1	announcement (ST-WT-ST)
	x	x	0	x	standard time (WT)
	x	x	1	x	daylight saving time(ST)
	x	0	x	x	no announcement leap second
	x	1	x	x	announcement leap second
	0	x	x	x	crystal operation
	1	x	x	x	radio operation
Day of the Week:	0	0	0	1	Monday
	0	0	1	0	Tuesday
	0	0	1	1	Wednesday
	0	1	0	0	Thursday
	0	1	0	1	Friday
	0	1	1	0	Saturday
	0	1	1	1	Sunday

Status	Operating Mode	Leap Second	Time	Change over ST-WT-ST
0 = 0000	quartz	no announcement	winter	no announcement
1 = 0001	quartz	no announcement	winter	announcement
2 = 0010	quartz	no announcement	summer	no announcement
3 = 0011	quartz	no announcement	summer	announcement
4 = 0100	quartz	announcement	winter	no announcement
5 = 0101	quartz	announcement	winter	announcement
6 = 0110	quartz	announcement	summer	no announcement
7 = 0111	quartz	announcement	summer	announcement
8 = 1000	radio	no announcement	winter	no announcement
9 = 1001	radio	no announcement	winter	announcement
A = 1010	radio	no announcement	summer	no announcement
B = 1011	radio	no announcement	summer	announcement
C = 1100	radio	announcement	winter	no announcement
D = 1101	radio	announcement	winter	announcement
E = 1110	radio	announcement	summer	no announcement
F = 1111	radio	announcement	summer	announcement

5.6.4 Example

(STX)831234560301968230(LF)(CR)(ETX)

- It is Wednesday 03.01.1996 - 12:34:56 o'clock
- radio operation
- standard time
- no announcement
- The difference time to UTC is +2.30 h

5.7 GPS2000 Data String

The GPS2000 Data String can be transmitted with all modes (e.g. with forerun or control character at second change).

5.7.1 Specified Settings



Attention

The order of CR and LF can not be changed.

5.7.2 Structure

Character No.	Meaning	Hex-Value	
1	SOH (start of header)	\$01	
2	hundreds day in the year	\$30-33	
3	tens day in the year	\$30-39	
4	unit day in the year	\$30-39	
5	":" (colon)	\$3A	
6	tens hours	\$30-39	
7	unit hours	\$30-36	
8	":" (colon)	\$3A	
9	tens minutes	\$30-33	
10	unit minutes	\$30-39	
11	":" (colon)	\$3A	
12	tens seconds	\$30-39	
13	unit seconds	\$30-39	
14	":" (colon)	\$3A	
	time accuracy		
	"?" (question mark)	inferior then 1msec	\$3F
	"#" (hash mark)	inferior then 100 µsec	\$23
15	"*" (asterisk)	inferior then 10 µsec	\$2A
	"." (point)	inferior then 1 µsec	\$2E
	" " (space)	better then 1 µsec	\$20
16	CR (carriage return)	\$0D	
17	LF (line feed)	\$0A	

5.7.3 Example

Example: **(SOH)042:12:34:56*(CR)(LF)**

It is day of the year 42, 12:34:56 hrs., the system time inaccuracy is greater than 10 µsec.

5.8 SAT 1703 Time String

The SAT 1703 Time String can be transmitted with all modes (e.g. with forerun or ETX to the second change).

The SAT 1703 Time String can also be transmitted on request. The point of transmission will be set to "transmission on request" and the data string can be requested by "?".

5.8.1 Specified Settings

No specified settings for this data string are necessary.

5.8.2 Structure

Character No.	Meaning	Hex-Value
1	STX (start of text)	\$02
2	tens day	\$30-33
3	unit day	\$30-39
4	"." (dot)	\$2E
5	tens month	\$30-31
6	unit month	\$30-39
7	"." (dot)	\$2E
8	tens year	\$30-39
9	unit year	\$30-39
10	"/" (slash)	\$2F
11	day of the week	\$31-37
12	"/" (slash)	\$2F
13	tens hour	\$30-32
14	unit hour	\$30-39
15	":" (colon)	\$3A
16	tens minute	\$30-35
17	unit minute	\$30-39
18	":" (colon)	\$3A
19	tens second	\$30-35
20	unit second	\$30-39

Character No.	Meaning	Hex-Value
21	"M" or "M" or "U"	\$4D, \$4D, \$55
22	"E" or "E" or "T" (standard time [CET], summer time [CEST] or UTC)	\$45, \$45, \$54
23	"Z" or "S" or "C"	\$5A, \$53, \$43
24	" " or "Z" or " "	\$20, \$5A, \$20
25	" " (\$20 ⇒ synchronous) or "*" (\$2A ⇒ not synchronous)	\$20 \$2A
26	" " (\$20 ⇒ no announcement) or "!" (\$21 ⇒ announcement of S/D- or D/S-changeover)	\$20 \$21
27	CR (carriage return)	\$0D
28	LF (line feed)	\$0A
29	ETX	\$03

5.8.3 Example

(STX) 18.07.02/4/02:34:45UTC__ (CR)(LF)(ETX)

- It is Thursday 18.07.2002 - 02:34:45 o'clock UTC
- The clock is synchronised

5.9 SINEC H1 Extended

The SINEC H1 Extended String can be transmitted with all modes (e.g. with forerun or ETX to the second change).

The SINEC H1 Extended String can also be transmitted on request. The point of transmission will be set to "transmission on request" and the data string can be requested by "?".

5.9.1 Specified Settings

No specified settings for this data string are necessary.

5.9.2 Structure

Character No.	Meaning	Hex-Value
1	STX (start of text)	\$02
2	"D" ASCII D	\$44
3	":" (colon)	\$3A
4	tens day	\$30-33
5	unit day	\$30-39
6	"." (dot)	\$2E
7	tens month	\$30-31
8	unit month	\$30-39
9	"." (dot)	\$2E
10	tens year	\$30-39
11	unit year	\$30-39
12	"," (semicolon)	\$3B
13	"T" ASCII T	\$54
14	":" (colon)	\$3A
15	day of the week	\$31-37
16	"," (semicolon)	\$3B
17	"U" ASCII U	\$55
18	":" (colon)	\$3A
19	tens hours	\$30-32
20	unit hours	\$30-39
21	"." (dot)	\$2E
22	tens minute	\$30-35
23	unit minute	\$30-39
24	"." (dot)	\$2E
25	tens seconds	\$30-35
26	unit seconds	\$30-39
27	"," (semicolon)	\$3B

Character No.	Meaning	Hex-Value
28	"#" (time invalid) or " " (clock min. in crystal operation)	\$23 \$20
29	"*" () or " " ()	\$2A \$20
30	"S" (summer time) or "U" (UTC) or " " (winter time)	\$53 \$55 \$20
31	"!" (announcement summer/winter time changeover) or "A" (announcement of a leap second) or " " (no announcement)	\$21 \$41 \$20
32	ETX (end of text)	\$03

5.9.3 Example

(STX)D:03.01.96;T:3;U:12.34.56; _ _ _ _ (ETX) (_) = Space

radio operation, no announcement, standard time
It is Wednesday 03.01.96 - 12:34:56 h

6 Examples of connections

6.1 Assignment of the screw clips

X1

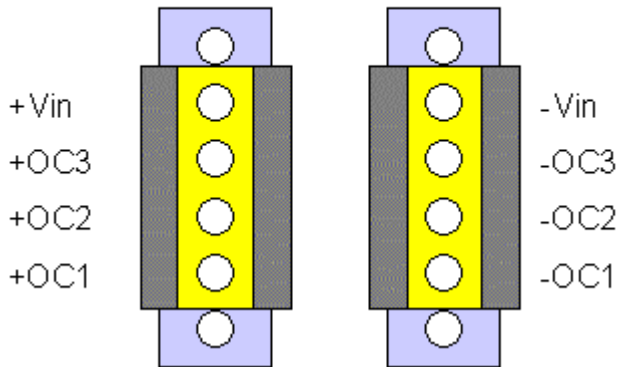

6.1.1 Examples of connections for OC1-3

Active, positive pulse

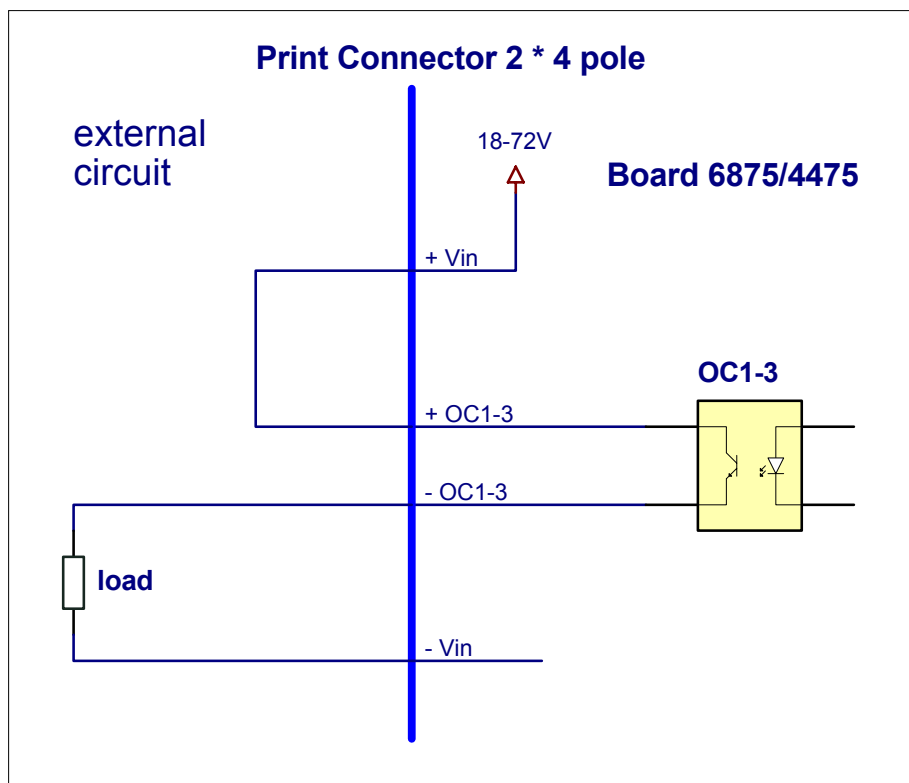

Active, negative pulse

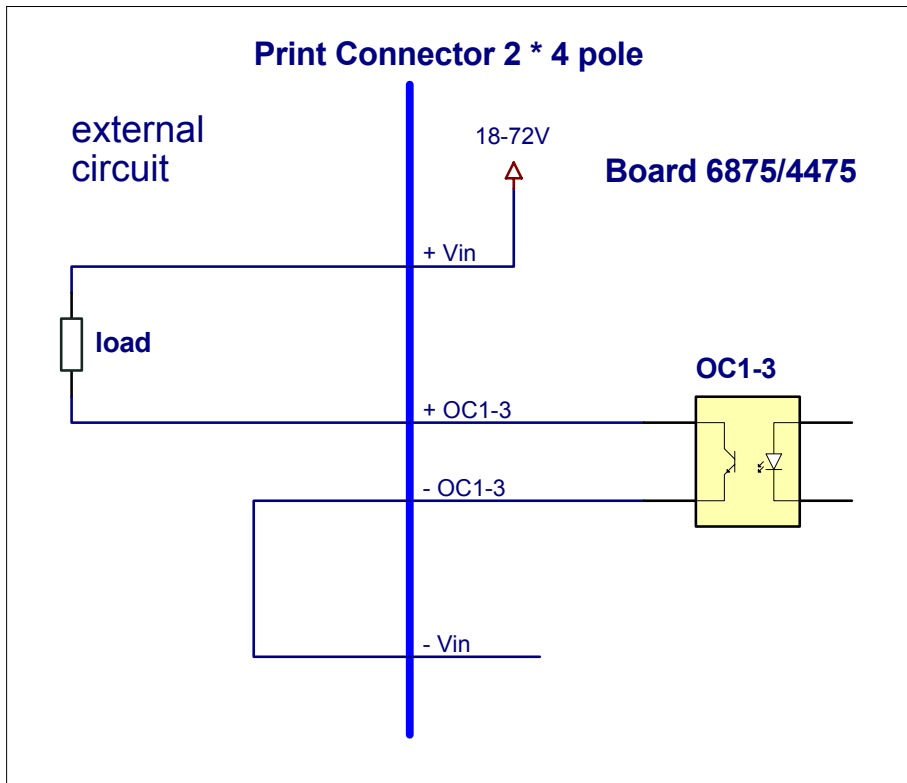

Passive, positive pulse

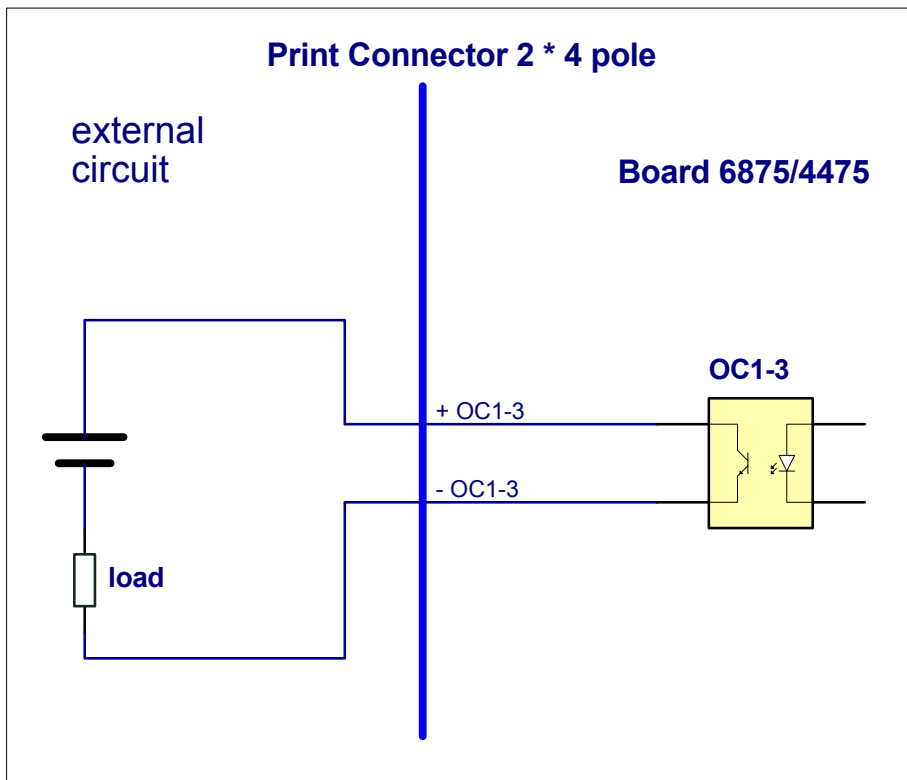

7 Glossary and abbreviations

UTC	Universal time coordinated
GPS	Global positioning system
DCF77	(D) Deutsches (German) (C) Langwellensignal (longwave signal) (F) Frankfurt a.M. (77) Frequency in kHz
PPS	Pulse Per Second
Standard time	Standard time - winter time
DST	Daylight Saving Time – summer time
IRIG-B	Inter-Range Instrumentation Options B
AFNOR	L'Association Française de Normalisation – French standards institute
IEEE	Institute of Electrical and Electronics Engineers