

Industriefunkuhren



Technical Manual

IRIG-B Output Board

Model 7266RC

ENGLISH

Version: 02.01 – 24.09.2009

Valid for Devices 7266RC with FIRMWARE Version: **02.xx**

Version number (Firmware / Manual)

THE FIRST TWO DIGITS OF THE VERSION NUMBER OF THE TECHNICAL MANUAL AND THE FIRST TWO DIGITS OF THE FIRMWARE VERSION MUST **COMPLY WITH EACH OTHER**. THEY INDICATE THE FUNCTIONAL CORRELATION BETWEEN DEVICE AND TECHNICAL MANUAL.

THE DIGITS AFTER THE POINT IN THE VERSION NUMBER INDICATE CORRECTIONS IN THE FIRMWARE / MANUAL THAT ARE OF NO SIGNIFICANCE FOR THE FUNCTION.

Downloading Technical Manuals

All current manuals of our products are available free of charge via our homepage on the Internet.

Homepage: <http://www.hopf.com>

E-Mail: info@hopf.com

Symbols and Characters



Operational Reliability

Disregard may cause damages to persons or material.



Functionality

Disregard may impact function of system/device.



Information

Notes and Information.



Safety regulations

The safety regulations and observance of the technical data serve to ensure trouble-free operation of the device and protection of persons and material. It is therefore of utmost importance to observe and compliance with these regulations.

If these are not complied with, then no claims may be made under the terms of the warranty and no liability will be assumed for any ensuing damage.



Safety of the device

This device has been manufactured in accordance with the latest technological standards and approved safety regulations

The device should only be put into operation by trained and qualified staff. Care must be taken that all cable connections are laid and fixed in position correctly. The device should only be operated with the voltage supply indicated on the identification label.

The device should only be operated by qualified staff or employees who have received specific instruction.

If a device must be opened for repair, this should only be carried out by employees with appropriate qualifications or by **hopf** Elektronik GmbH.

Before a device is opened or a fuse is changed all power supplies must be disconnected.

If there are reasons to believe that the operational safety can no longer be guaranteed the device must be taken out of service and labelled accordingly.

The safety may be impaired when the device does not operate properly or if it is obviously damaged.

CE-Conformity



This device fulfils the requirements of the EU directive 89/336/EWG "Electromagnetic compatibility" and 73/23/EWG "Low voltage equipment".

Therefore the device bears the CE identification marking (CE=Communauté Européenne)

CE = Communautés Européennes = European communities

The CE indicates to the controlling bodies that the product complies with the requirements of the EU directive - especially with regard to protection of health and safety for the operator and the user - and may be released for sale within the common markets.

Contents	Page
1 General Description of Functions	7
2 IRIG-B Format	7
2.1 Signal Output	7
2.2 IRIG Standard 200-98, Timing Diagram.....	7
2.2.1 Format Categories IRIG-Bxxx.....	8
2.3 IRIG-B Extensions.....	9
2.3.1 IRIG IEEE 1344-1995	9
2.3.2 AFNOR NFS 87-500	9
3 Hardware	10
3.1 Front Panel 3U/4HP	10
3.2 Board Configuration	11
3.3 VG-Strip Connector 64-pole (DIN 41612)	12
4 Embedding the Board 7266RC in the System 7001RC	14
4.1 Identification of the Board Numbers available.....	14
4.2 Set the Board Number	14
4.3 Installation of a new Board 7266RC in the System 7001RC.....	15
4.4 Parametrize / Activating the Board 7266RC in the System 7001RC.....	16
4.5 Activating the Board in the System 7001RC	16
5 Administration of the Board 7266RC	17
5.1 Input Functions for the Board 7266RC in the System 7001RC.....	17
5.1.1 Parameter Byte Input - Parameter Byte 01.....	18
5.1.1.1 Controlling the 2 nd Digital Output D2 (IRIG-B/PPS/DCF77).....	18
5.1.1.2 Select UTC/Local Time in the IRIG-B String	18
5.1.1.3 Switch on/off Binary Day Seconds in the Data String	18
5.1.1.4 Mode Setting (AFNOR/IRIG-B)	18
5.1.2 Enter Parameter Byte 02	19
5.1.2.1 Bit 7-0, (without Function at present)	19
5.1.3 Enter Parameter Byte 03	19
5.1.3.1 Bit 7-0, (without Function at present)	19
6 Technical Data	20
7 Glossary	20

1 General Description of Functions

Serial output of time information with the 7266 board is in IRIG format. There are varying IRIG time codes which differ as to the repeatability frame and the number of bits transmitted. They are identified by means of the attachment of a letter in alphabetical order A, B, C, D etc.. The most frequently used time frame is the IRIG-B Code. A choice of hardware interfaces and data formats is available on the 7266 board. The following IRIG-B formats are available for the board 7266RC:

- IRIG IEEE 1344-1995
- AFNOR NFS 87-500



The IRIG-B 200-1995 Standard is contained as a subset in both modes.

2 IRIG-B Format

2.1 Signal Output

Serial output can be a TTL level (IRIG-B 00x) or an analogue amplitude-modulated signal (IRIG-B 123).

With analogue output the positive zero cycle of a sinus oscillation is modulated with the rising edge of the IRIG-B signal.

The rate of modulation for the signal information of H/L level should be between 3:1 and 6:1. The board 7266RC has a rate of modulation of 3:1.

2.2 IRIG Standard 200-98, Timing Diagram

The IRIG-B format consists of one time code with 74 bits and has a repeatability rate of one second. The bit frame is 10 msec. The rating of a bit is displayed by a pulse width modulation and is shown in multiples of a millisecond.

To synchronize to the beginning of a second a neutral logic status is required which is called the identifier.

Logic 0	= 2 msec H-level
Logic 1	= 5 msec H-level
Identifier	= 8 msec H-level

The 74 time code bits are divided into

- 30 bits for the BCD value of seconds, minutes, hours and the current day of year
- 27 bits for the input of control information
- 17 bits for the binary value of the current seconds of day

100 bit frames can be transmitted in one second. Unused bit frames are refilled with a logical zero.

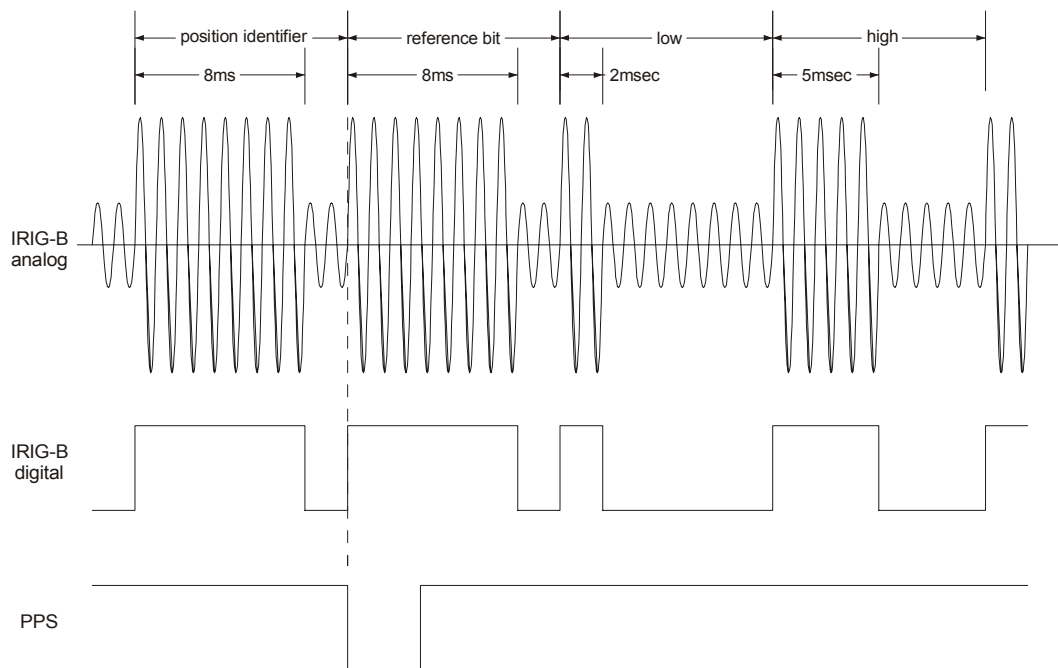

2.2.1 Format Categories IRIG-Bxxx

Signal output can be digital or analogue and also with different data content. The variations are indicated by attaching a three-digit combination of figures.

The figures have the following meaning:

Figure 1	0	= digital output
	1	= analogue output via carrier
Figure 2	0	= no carrier
	1	= carrier 100 Hz
	2	= carrier 1000 Hz
Figure 3	0	= data content of complete time code with 74 bits
	1	= data content time information 30 bit + control information 27 bit
	2	= data content time information 30 bit
	3	= data content time information 30 bits + binary seconds of day 17 bit

e.g. **IRIG-B123** = analogue output, carrier 1000 Hz,
= data content time information and binary seconds of day

2.3 IRIG-B Extensions

2.3.1 IRIG IEEE 1344-1995

This IRIG standard is based on IRIG Standard 200-1995. Fixed data such as year, time offset etc. are assigned to the 27 bits of the control information field. The IRIG Standard 200-98 is contained as a subset in both modes.

2.3.2 AFNOR NFS 87-500

This IRIG standard has been laid down by the French institute for standards. It is based on Standard IRIG-B 200. Fixed data such as year, month etc. are assigned to the 27 bits of the control information field. The IRIG Standard 200-98 is contained as a subset in both modes.

3 Hardware

3.1 Front Panel 3U/4HP

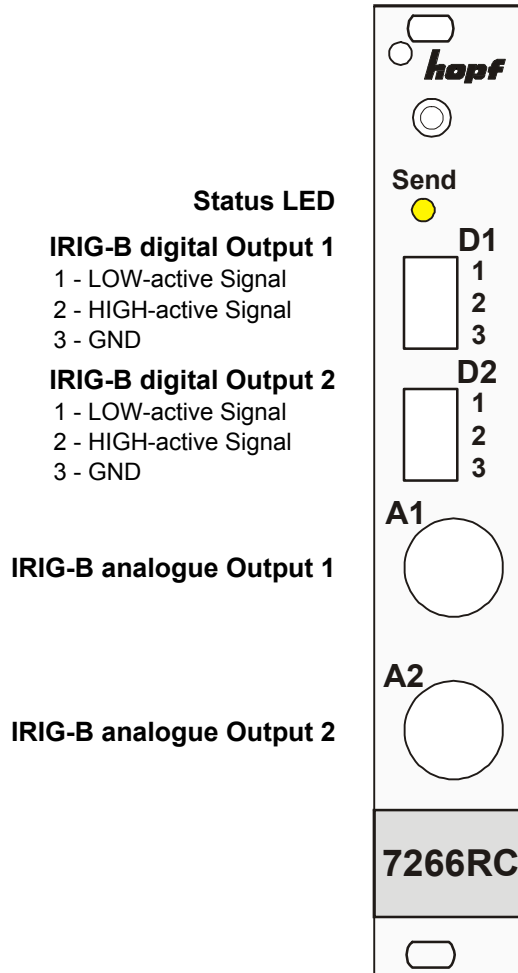

On the front panel the two digital outputs are identifiable as sockets D1/D2 and the two analogue outputs as BNC connectors A1/A2. Optionally the digital and/or analogue outputs can be supplied **potential isolated**.

For the load capacity of the outputs please refer to the technical data.

3.2 Board Configuration

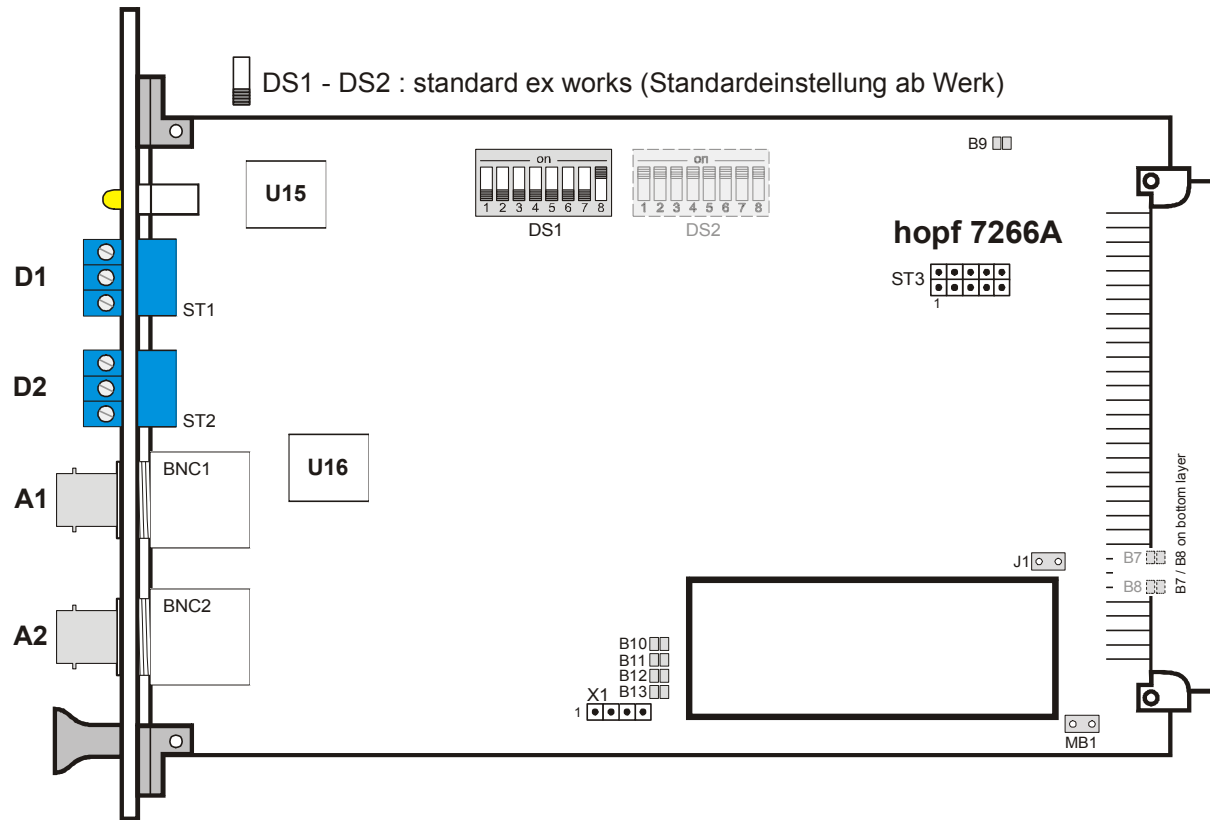

			def.	user
Jumper J1	closed (zu)	only for factory use (nur für werksinterne Einstellungen)	<input type="checkbox"/>	<input type="checkbox"/>
	opened (offen)	only for factory use (nur für werksinterne Einstellungen)	<input checked="" type="checkbox"/>	<input type="checkbox"/>
Jumper MB1	closed (zu)	only for factory use (nur für werksinterne Einstellungen)	<input type="checkbox"/>	<input type="checkbox"/>
	opened (offen)	only for factory use (nur für werksinterne Einstellungen)	<input checked="" type="checkbox"/>	<input type="checkbox"/>

B7-B8 on the bottom layer (B7-B8 auf der Bestückungsseite)

			def.	user
B7	closed (zu)	only for factory use (nur für werksinterne Einstellungen)	<input type="checkbox"/>	<input type="checkbox"/>
	opened (offen)	only for factory use (nur für werksinterne Einstellungen)	<input checked="" type="checkbox"/>	<input type="checkbox"/>
B8	closed (zu)	only for factory use (nur für werksinterne Einstellungen)	<input type="checkbox"/>	<input type="checkbox"/>
	opened (offen)	only for factory use (nur für werksinterne Einstellungen)	<input checked="" type="checkbox"/>	<input type="checkbox"/>

			def.	user
B9	closed (zu)	only for factory use (nur für werksinterne Einstellungen)	<input checked="" type="checkbox"/>	<input type="checkbox"/>
	opened (offen)	only for factory use (nur für werksinterne Einstellungen)	<input type="checkbox"/>	<input type="checkbox"/>
B10	closed (zu)	only for factory use (nur für werksinterne Einstellungen)	<input type="checkbox"/>	<input type="checkbox"/>
	opened (offen)	only for factory use (nur für werksinterne Einstellungen)	<input checked="" type="checkbox"/>	<input type="checkbox"/>
B11	closed (zu)	only for factory use (nur für werksinterne Einstellungen)	<input type="checkbox"/>	<input type="checkbox"/>
	opened (offen)	only for factory use (nur für werksinterne Einstellungen)	<input checked="" type="checkbox"/>	<input type="checkbox"/>
B12	closed (zu)	only for factory use (nur für werksinterne Einstellungen)	<input type="checkbox"/>	<input type="checkbox"/>
	opened (offen)	only for factory use (nur für werksinterne Einstellungen)	<input checked="" type="checkbox"/>	<input type="checkbox"/>
B13	closed (zu)	only for factory use (nur für werksinterne Einstellungen)	<input type="checkbox"/>	<input type="checkbox"/>
	opened (offen)	only for factory use (nur für werksinterne Einstellungen)	<input checked="" type="checkbox"/>	<input type="checkbox"/>

3.3 VG-Strip Connector 64-pole (DIN 41612)

Row B unassigned!

Pin no.	ROW A		ROW B		ROW C	
	Signal	connection	Signal	connection	Signal	connection
1						
2						
3					IO01	
4					IO02	
5					ERRO	
6	IRIG Pulse In 1				IRIG Pulse Out 1	
7	RTN GND				RTN GND	
8	IRIG Pulse In 2				IRIG Pulse Out 2	
9	RTN GND				RTN GND	
10	IRIG SIN In				IRIG SIN Out	
11	GND A				GND A	
12						
13						
14						
15						
16						
17						
18						
19						
20						
21					RESB	
22					DCFT	
23	SCLK				SERI	
24	SECB				KHZB	
25	FRIN				FROU	
26						
27	ARIN				AROU	
28						
29						
30						
31	GND				GND	
32	VCC				VCC	

3.4 Board 7266RC Slave

There are only the output functions from the master board 7266RC available on the board 7266RC slave. This board can not be used stand-alone. It can be used to duplicate the signals from the master board. Until eight slave boards can be connected behind a master board. The digital and analogue outputs have the same technical data as the master board.



The board 7266RC slave is not programmable via the HMC remote software!

3.4.1 Front Panel 3U/4HP

See *chapter 3.1 Front Panel 3U/4HP*, however without status LED.

3.4.2 Board Configuration

The are no settings necessary on the board 7266RC slave.

3.4.3 VG-Strip Connector 64-pole (DIN 41612)

Row a/c assigned!

Pin no.	ROW A		ROW B		ROW C	
	Signal	connection	Signal	connection	Signal	connection
1						
2						
3						
4						
5						
6	IRIG Pulse In 1					
7	RTN GND					
8	IRIG Pulse In 2					
9	RTN GND					
10	IRIG SIN In					
11	GND					
12						
13						
14						
15						
16						
17						
18						
19						
20						
21						
22						
23						
24						
25						
26						
27						
28						
29						
30						
31	GND				GND	
32	VCC				VCC	

4 Embedding the Board 7266RC in the System 7001RC



This chapter describes the implementing of an additional RC-Function Board into the System 7001RC. In a new delivered System 7001RC all System Boards are already implemented and pre-configured with the **hopf** default settings as a rule.

All RC function boards are individually parameterized from the system 7001RC.



Every RC function board is uniquely identified via the board type and an assigned board number (1-31)

The following steps are necessary for implementation:

- Identification of the board numbers available
- Setting up of the board number with the DIP switch on the board 7266RC
- Installation of the board 7266RC in the system 7001RC
- Parameterization of the board 7266RC
- Activation of the board 7266RC via the system 7001RC

4.1 Identification of the Board Numbers available

The board numbers allocated so far can be displayed via the **SHOW ALL ADDED SYSTEM-BOARDS** menu. The board numbers that are not listed for this board type are available for the new board.



Boards that are available in terms of hardware, but which have not yet been activated via the system menu, are **not** listed in the **SHOW ALL ADDED SYSTEM-BOARDS** menu. (The "SEND" LED of these boards does not flash when in operation.)

In order to identify the set board number, these boards must be made available externally, in order to identify the set board number from the DIP switch setting.

4.2 Set the Board Number

In order to clearly identify the board in the system 7001RC, the board number must be defined via the DS1 DIP switch bank. The board number is set as Hex code on DS1. Switch 8 is the lowest value bit and switch 1 the highest value bit. The inscription on the DIP switch housing serves to identify switches 1-8. Board numbers from 1 to 31 can be setup, board numbers outside this range are not recognized by the system 7001RC.



Under no circumstances may two boards of the same type with the same board number be embedded in one system 7001RC. This leads to undefined errors on both boards.

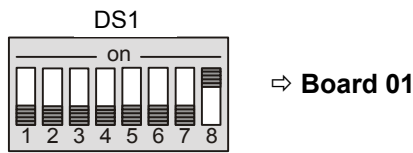

DS1 Pos 4	DS1 Pos 5	DS1 Pos 6	DS1 Pos 7	DS1 Pos 8	board number in System 7001RC
off	off	off	off	on	1
off	off	off	on	off	2
off	off	off	on	on	3
off	off	on	off	off	4
off	off	on	off	on	5
off	off	on	on	off	6
off	off	on	on	on	7
off	on	off	off	off	8
off	on	off	off	on	9
off	on	off	on	off	10
off	on	off	on	on	11
off	on	on	off	off	12
off	on	on	off	on	13
off	on	on	on	off	14
off	on	on	on	on	15
on	off	off	off	off	16
on	off	off	off	on	17
on	off	off	on	off	18
on	off	off	on	on	19
on	off	on	off	off	20
on	off	on	off	on	21
on	off	on	on	off	22
on	off	on	on	on	23
on	on	off	off	off	24
on	on	off	off	on	25
on	on	off	on	off	26
on	on	off	on	on	27
on	on	on	off	off	28
on	on	on	off	on	29
on	on	on	on	off	30
on	on	on	on	on	31

4.3 Installation of a new Board 7266RC in the System 7001RC

In order to install a new board 7266RC, a free extension slot (slot with board connectors and VG strip installed in the system bus) must be available. This information can be obtained from the associated specific system drawing.

If no free extension slot is available, this can usually be retrofitted. Please contact **hopf** Elektronik GmbH.

4.4 Parametrize / Activating the Board 7266RC in the System 7001RC

The following steps are required to activate the board:



To avoid undesirable output behaviour of the board it is first parameterized and then activated by switching it into the monitoring system.

- In **BOARD-SETUP** menu, sub-heading **ADD SYSTEM-BOARDS**, log on the newly installed board.
- In **BOARD-SETUP** menu, sub-heading **SET SYSTEM BOARDS PARAMETER** parameterize the board.
- In **BOARD-SETUP** menu, sub-heading **SET SYSTEM BOARDS TO MONITORING-MODE OR IDLE-MODE** integrate the newly installed board into the monitoring system.



The menus:

- **ADD SYSTEM-BOARDS** and
- **SET SYSTEM BOARDS TO MONITORING-MODE OR IDLE-MODE**

can be consulted in the technical specification of the system 7001RC.

4.5 Activating the Board in the System 7001RC

The following steps are necessary to activate the board:

- In **BOARD-SETUP** menu, sub-heading **ADD SYSTEM-BOARDS Y/N**, login the newly installed board.
- In **BOARD-SETUP** menu, sub-heading **SET SYSTEM BOARDS PARAMETER** parameterise the board.
- In **BOARD-SETUP** menu, sub-heading **SET SYSTEM BOARDS TO ACTIVATE THE MONITORING-MODE OR IDLE-MODE Y/N** embed the newly installed board into the monitoring system.

Further information is available in the technical manual of the system 7001RC.

5 Administration of the Board 7266RC

The technical manual of the System 7001RC is the basis for the configuration. Successional only the input of values are described which are located in the menu **BOARD-SETUP : 4**.



All parameters can be activated also in the system 7001RC with the associated **hopf** 7001RC Remotesoftware (see technical description **hopf** 7001RC Remotesoftware).



The menu **SET SYSTEM-BOARDS PARAMETER** has to be completely finished by pressing the **ENT** key so that the System 7001RC accepts the newly configured parameters.

5.1 Input Functions for the Board 7266RC in the System 7001RC

The input and display functions of the board parameters are polled in the menu heading **BOARD-SETUP : 4**

- with **ENT** key ⇒ Main menu
- with **4** key ⇒ Board setup
- with **N** key ⇒ Scroll to menu heading:

```

SET SYSTEM-BOARDS PARAMETER Y/N
  
```

Select with key **Y**

Search for board to be parameterized with key **N** and select with key **Y**

Example:

```

PARAMETER BOARD 03 OF 25 7266 NR.: 01
STATUS: I/E BOARDNAME: "IRIG" SET>Y/N
  
```

- PARAMETER BOARD 03 OF 25** ⇒ Board 03 of a total of 25 implemented boards
- 7266 NR.: 01** ⇒ board type **7266RC** with board number **01**
- STATUS: M (I)/- (E)** ⇒ **M** = monitoring / **-** = without error operating - **or**
- ⇒ **I** = no monitoring / **E** = board error
- BOARDNAME: "IRIG____"** ⇒ Board name freely selectable by customer

5.1.1 Parameter Byte Input - Parameter Byte 01

Various board parameters are set using the parameter byte menu. A function is allocated to each bit. These functions are explained in the following tables. A function is activated with **1** and deactivated with **0**.

```

B . 7 2 6 6 N O . : 0 1       O L D :   B Y T E   0 1 > 0 0 0 0 1 1 1 1 <
B Y T E   =   B I T   7 . . 0   N E W :   B Y T E   0 1 > 0 1 1 0 0 0 0 0 <
    
```

The current parameter byte is shown in the upper line with its number (01) and the preset values. The bits of the parameter byte are numbered in descending order:

```

B Y T E   0 1 > 7 6 5 4 3 2 1 0 <
    
```

By pressing **(ENT)**er it is possible to jump straight to Parameter Byte 02 without making any changes to Parameter Byte 01. To make a change the individual bits of the new byte are to be entered in the second line with **"0"** and **"1"**. The complete parameter byte must always be entered and confirmed with **(ENT)**er.



Parameter Byte 01 BIT 7, 4, 3, 2 and Parameter Byte 02 have no function.

5.1.1.1 Controlling the 2nd Digital Output D2 (IRIG-B/PPS/DCF77)

Bit 6	Bit 5	Function
1	1	IRIG-B output
1	0	DCF77 pulse output
0	1	PPS signal output
0	0	IRIG-B output

5.1.1.2 Select UTC/Local Time in the IRIG-B String

Bit 2	Function
1	UTC is the basis for the data string
0	Local time is the basis for the data string

5.1.1.3 Switch on/off Binary Day Seconds in the Data String

Bit 1	Function
1	Binary day seconds are switched off in the data string. Logic 0 bit frames are transmitted
0	Binary day seconds are transmitted in the data string.

5.1.1.4 Mode Setting (AFNOR/IRIG-B)

Bit 0	Function
1	AFNOR NFS 87-500 is output as a serial string
0	IRIG-B IEEE 1344-1995 is output as a serial string



The IRIG-B 200-1995 Standard is contained as a subset in both modes.

5.1.2 Enter Parameter Byte 02

Parameter byte 02 is shown on the upper line with the currently set values.

```
B . 7 2 6 6 N O . : 0 1 O L D : B Y T E 0 2 > 0 0 0 0 0 0 0 0 <
B Y T E = B I T 7 . . 0 N E W : B Y T E 0 2 > _ _ _ _ _ _ _ _ <
```

In order to make a change, the individual bits of the new byte are entered on the second line, using "0" and "1". The complete parameter byte must always be registered and confirmed by pressing the **ENT** key.

The bits of the parameter byte are numbered in descending order:

```
B Y T E 0 2 > 7 6 5 4 3 2 1 0 <
```

Bit 7-0	Currently without a function
0	For compatibility reasons these bits must always be set to "0".

5.1.2.1 Bit 7-0, (without Function at present)

Bits 7-0 are without a function at present. For compatibility reasons these bits must always be set to "0".

5.1.3 Enter Parameter Byte 03

Parameter byte 03 is shown on the upper line with the currently set values.

```
B . 7 2 6 6 N O . : 0 1 O L D : B Y T E 0 3 > 0 0 0 0 0 0 0 0 <
B Y T E = B I T 7 . . 0 N E W : B Y T E 0 3 > _ _ _ _ _ _ _ _ <
```

In order to make a change, the individual bits of the new byte are entered on the second line, using "0" and "1". The complete parameter byte must always be registered and confirmed by pressing the **ENT** key.

The bits of the parameter byte are numbered in descending order:

```
B Y T E 0 3 > 7 6 5 4 3 2 1 0 <
```

Bit 7-0	Currently without a function
0	For compatibility reasons these bits must always be set to "0".

5.1.3.1 Bit 7-0, (without Function at present)

Bits 7-0 are without a function at present. For compatibility reasons these bits must always be set to "0".

6 Technical Data

Board dimensions	Euro board 100mm x 160mm, 3U / 4HP
Power supply	5V DC \pm 5% (via system bus)
Charging rate	approx. 390 mA
Temperature range	
Storage	- 30 ... + 85 °C
Operation	0 ... + 70 °C
Humidity	95 %, no dew
Standards	CE
Protection category	none
MTBF	> 450.000 hrs.
Electrical features (on VG plug connector): Inputs / outputs	TTL compatible
Load capacity of the analogue outputs:	3 V_{ss} to 50 Ω 5 V_{ss} to 600 Ω
Load capacity of the digital outputs:	
When operating as RS422 outputs:	32 RS422 Listener
as TTL outputs low active:	+40 mA
as TTL outputs high active:	-20 mA

7 Glossary

GPS	Global Positioning System
UTC	Universal Time Coordinated with correction of the leap second
GPS-UTC	Continuous world time without correction of the leap second
IRIG	Inter Range Instrumentation Group
AFNOR	Association française de normalisation
NTP	Network Time Protocol
3D	three dimensional determination of position, longitude, latitude and altitude
GHz	one billion Hertz
ppb	part per billion = 1E -9
ppm	part per million = 1E -6
msec	one thousandth second
μ sec	one millionth second